

AGRICULTURAL MACHINERY

sitrex®
s.r.l.

**ASSEMBLING USE AND
MAINTENANCE
SPARE PARTS LIST**

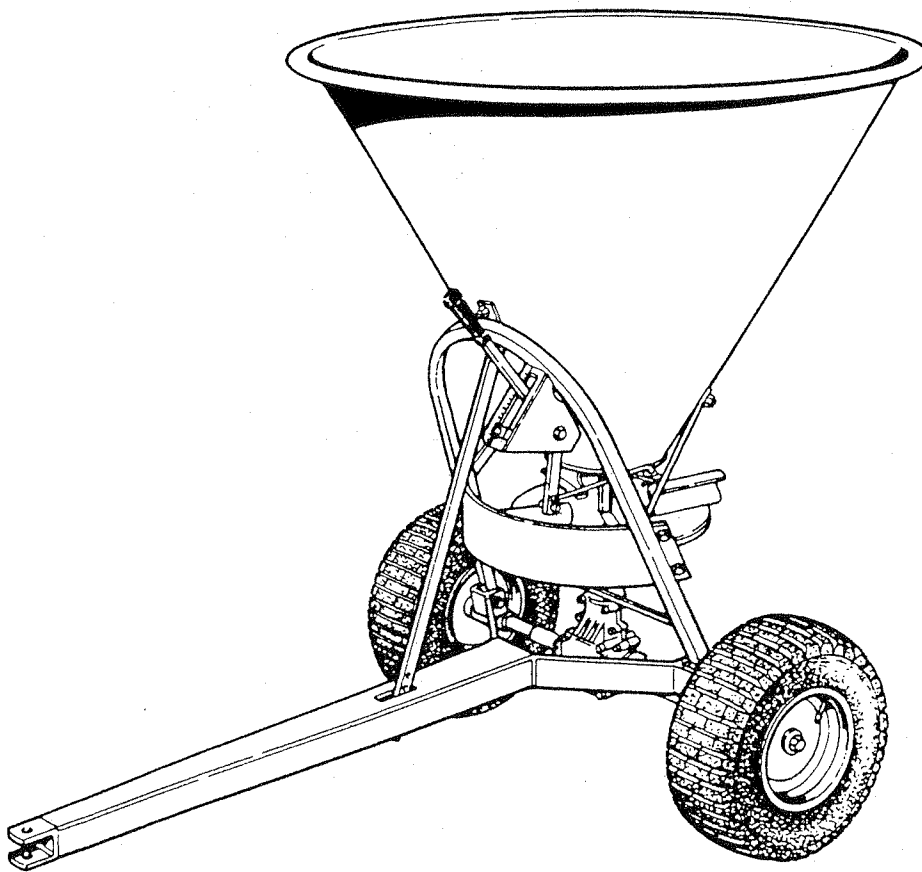

FSP 100/150

1 - FOREWORD

1.1 This manual is an integral part of the machine and contains information necessary for its operation and maintenance.

Operators and maintenance staff are advised to read the manual before using the machine or carrying out any maintenance.

This booklet, or a copy of it, must always be available for the operator to consult.

For any further information please contact the manufacturer.



1.2 Take care when you see this symbol: it indicates the operations which are dangerous.



1.3 This is a sign for a note or warning.

2 - IDENTIFICATION LABELS

2.1 The identification label of the machine carrying all identification details is positioned on the protective casing. (Fig.1 pag. 7).

2.2 The labels in (Fig.2 pag. 7) are applied to the hopper, frame and casing as shown in (Fig.3 pag. 7).

2.3-DESCRIPTION OF THE LABELS

- 1- Warning: before carrying out any maintenance, remove the ignition key from the tractor and read the instruction and maintenance manual.
- 2- Warning, remain at a distance. Danger from scattered product.
- 3- Warning: read the instruction and maintenance manual carefully.
- 4- Always use protective goggles and wear protective gloves.
- 5- Warning: keep hands away from rotating parts while the machine is operating.
- 6- This indicates the rotation speed in r.p.m.

Both the labels and the danger symbols must always be clean and in good condition; if necessary, replace with other originals available on request from the manufacturer.

3 - WARRANTY

The warranty is valid for 6 months from the date of purchase. The warranty is no longer valid in the event of the machine being improperly used. The warranty is no longer valid if the instruction in this booklet are not respected, if any changes are effected or spare parts which are not originals fitted.

4- DESCRIPTION OF THE MACHINE

This is a spreader with centrifugal action for dry or damp granular or non-granular materials, to be towed by a tractor or self-propelled vehicle. The centrifugal action is generated by the rotation of a disc with four blades positioned on the circumference.

4.1 MACHINE PARTS

The machine is essentially composed of: (Fig.4 pag. 7):

- SPREADING DISC EQUIPPED WITH BLADES..... 1
- FRAME WITH DRAWBAR..... 2
- LOADING HOPPER..... 3

5- ACCIDENT PREVENTION REGULATIONS

5.1 HOW TO AVOID ACCIDENTS

* In order to avoid accident it is necessary to pay attention to the indications on the labels applied to the machine and read this manual carefully.

Always take care that there are no animals or people (especially children) within the range of action of fertilizer spreader.

- * Always wear well-fastened, tight-fitting clothes, sturdy safety footwear, protective gloves, a mask and goggles if powdered fertilizer is being spread, especially in windy weather.

When the machine is at a standstill, switch off the motor and apply the parking brake.



Never carry out maintenance while the machine is operating.

- * When circulating on roads it is necessary to respect the highway code in force in that particular country.

Transporting people is prohibited both when working and during transfers.

Acoustic level below 70dB.

Always remember that a careful operator is the best safety device to prevent any kind of accident.

6 - USE OF THE MACHINE

The machine can be attached to any type of self-propelled vehicle or tractor which is sufficiently powerful.

6.1 MACHINE OPERATION

The machine must only be started up in the open and when there is enough visibility to see the distance to which the product is being spread.

6.2 PROHIBITED USES

The hopper must never be loaded with wet products as these could clog the machine. Never use the fertilizer spreader to scatter stones or other objects.

- * The fertilizer spreader must never be used by employees under the age of eighteen.

6.3 LOADING

Before loading the hopper the self-propelled vehicle or tractor must be switched off and the parking brake applied.

- * It is advisable for the same operator to load the hopper after having switched off the tractor motor.

6.4 REGULATING THE QUANTITY SUPPLIED

The quantity of product scattered can be increased or decreased by means of the opening lever. The quantity is increased by pushing the lever downwards and decreased by pulling it upwards, until the supply is shut off. (Fig.5 pag. 8)

6.5 DISC WITH ADJUSTABLE BLADES

According to the specific weight of the fertilizer to be spread, it is possible to direct the blades by moving them in the special clamps from N° 1 to N° 5, to obtain even scattering to the right and left. The blades are normally in position N° 3. By moving the blades towards N° 1 the scattering range to the left of the driver is increased. By moving them towards clamp N° 5 the scattering range to the right of the driver is increased. (Fig.6 pag.8)

7- ASSEMBLING THE FERTILIZER SPREADER (Fig.7 pag. 8)



Operators must take great care over this operation.

*

Use protective gloves and suitable tools in good condition.

- A- Assemble shafts 3-4 and 5 on the transmission unit, with the same rotation direction as shown in the drawing.
- B- Fix the transmission unit 1 to the frame 2.
- C- Fix the drawbar 6 to the frame 2.
- D- Fix the tie-rod 7 and the casing P to the frame 2.
- E- Fit the disc 8 on the central transmission shaft.
- F- Fix the fertilizer opening lever 9 to the bow on the frame 2.
- G- Fit the space washer 10 on the unit axle .
- H- Fix the wheels 11 to the unit axle.
- I - Fit the agitator guide bushing in the hopper cone, with the doser disc, the sealing washer and the snap ring. (N°14) .
- L- Introduce the agitator 15 into the central hole in the hopper 17 and fix it to the shaft 5; fit the casing 16 on the attachment holes of the hopper and fix the hopper to the frame 2.
- M- Connect the opening tie-rod 18 to the doser disc and the opening lever 9.

7.1 CONNECTION TO THE TRACTOR

Fasten the drawbar to the tractor using the special pin. (Fig.8 pag. 9)

8 - ACCESSORIES

The fertilizer spreader can be equipped with the following accessories:

- MANUAL TOWING KIT
- SALT AND SAND SPREADER CONE

8.1 MANUAL TOWING KIT

This accessory allows the fertilizer spreader to be easily manoeuvred once it has been detached from the tractor. (Fig.9 pag. 9)

8.2 SALT AND SAND SPREADER CONE

This is composed of a steel cone section with two adjustable side supports which hook onto the frame. By varying the height of the cone the scattering range is regulated, making it possible to scatter the product over the area beneath the hopper. (Fig.10 pag. 9)

9 - MAINTENANCE

- * All maintenance operations must be carried out by skilled personnel strictly adhering to the instructions given in this booklet.



Before carrying out any maintenance disconnect the spreader from the tractor.

- * Always clean the work area before carrying out any maintenance or checks. Use suitable tools in good condition and wear protective gloves.

9.1 ORDINARY MAINTENANCE

Before starting work, check that there are no foreign bodies in the hopper. Wash the machine and dry with compressed air every time after use

9.2 PROGRAMMED MAINTENANCE

Every 50 hours:

- Check that the screws are tight.
- Grease moving parts.

10 - STORAGE

At the end of each season, or in the event of long periods of disuse it is necessary to:

- Wash and dry the machine thoroughly.
- Carefully check and replace any worn or damaged parts.
- Tighten all bolts.
- Grease well in order to avoid rusting.
- Park the machine, in a closed area if possible, and cover it over, after having blocked it to avoid accidental movement or tipping.

Only the user will benefit from finding the machine in perfect condition after a period of disuse.

11- TRANSPORTING THE MACHINE

The machine is supplied disassembled and packed in cardboard and polythene: therefore read this instruction and maintenance booklet carefully.

Dispose of the packing properly in bins provided for this purpose.

12- TECHNICAL SPECIFICATIONS

12.1 OVERALL DIMENSION

MODEL	HEIGHT	WIDTH	WEIGHT	CAPACITY
FSP 100	3' 3" 3/8	2' 9" 1/2	100 LBS	26 GAL.
FSP 150	3' 5" 3/8	2' 9" 1/2	135 LBS	38 GAL.

12.2 TECHNICAL DATA

-REQUIRED POWER

For all models.....3 Kw

-SPREADING RANGE

2-6 m. according to the speed and the type of fertilizer

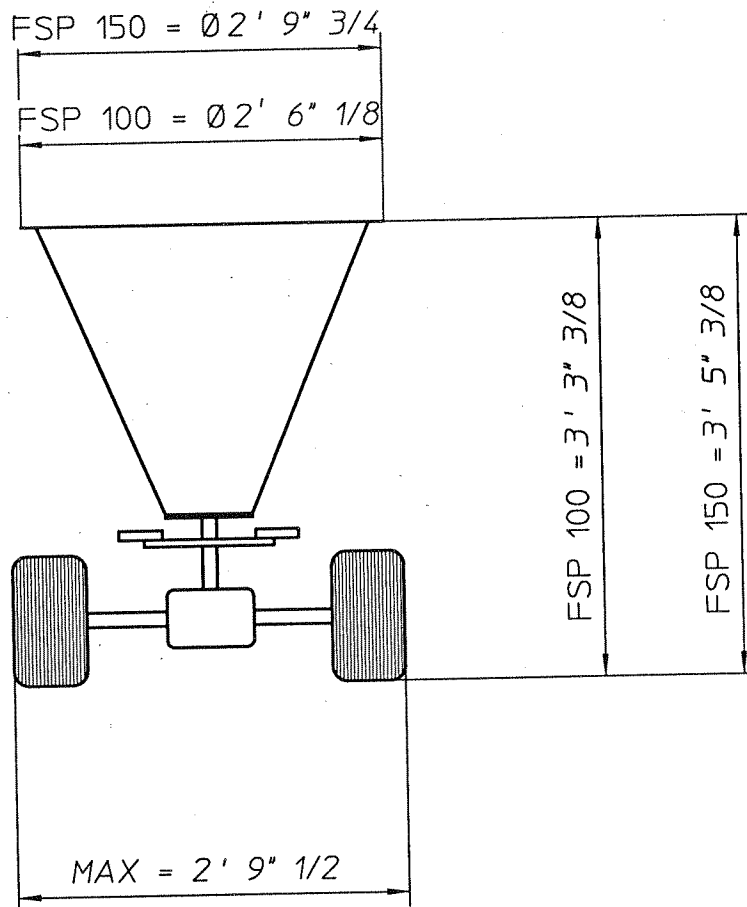

13- DISPOSAL OF THE MACHINE

Take the machine to a wrecker at the end of its life-span; do not discard any part of the machine into the environment. It could pollute the environment in which we live and become a hazard to anyone coming into contact with it.

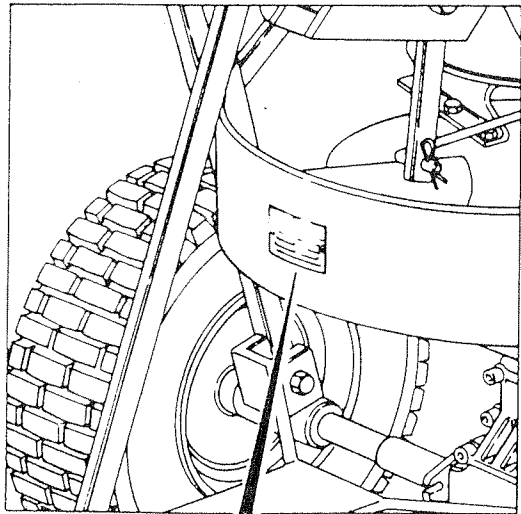

MARCA DE CONSTRUCȚOR / BRANDA CONSTRUCTION YEAR / ANNO DI COSTRUZIONE NR. DE SERIE / CODICE / SERIAL NR. MATRICOLA _____ _____ _____ _____ _____
--

FIG.1

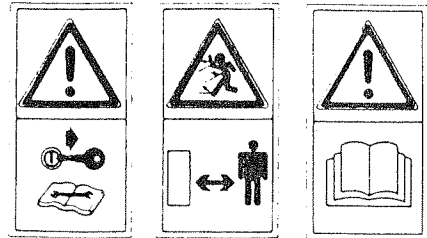

1

2

3

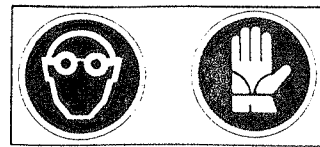

4

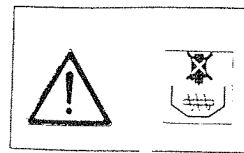

5

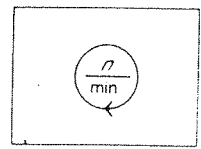

6

FIG.2

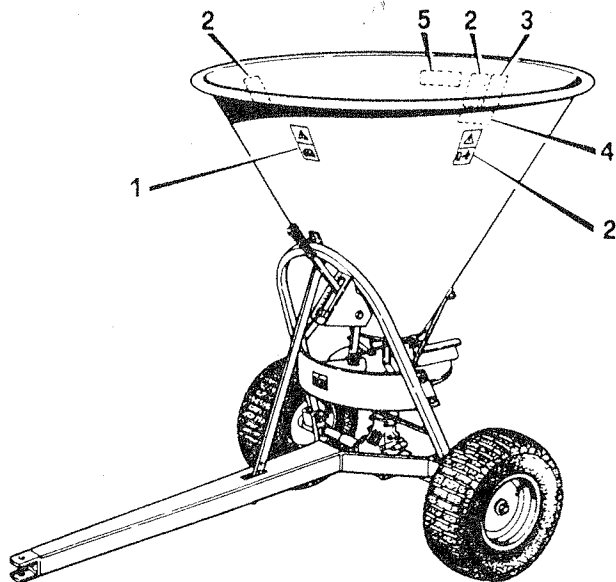

FIG.3

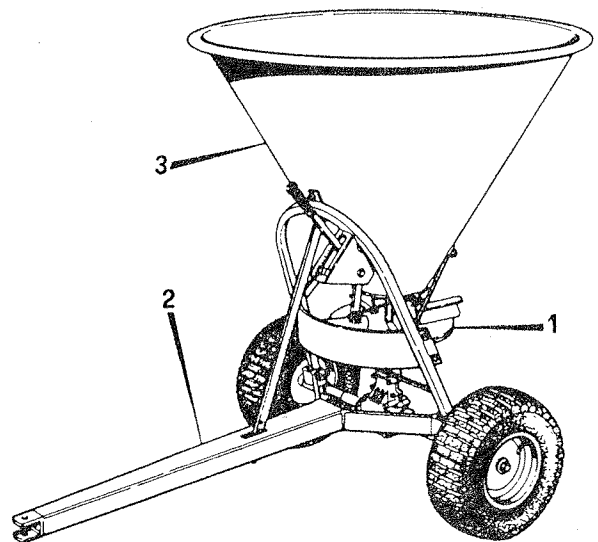

FIG.4

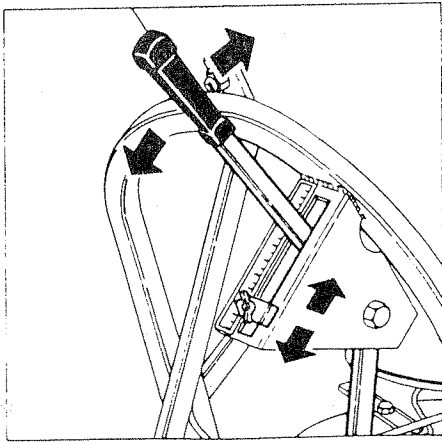

FIG. 5

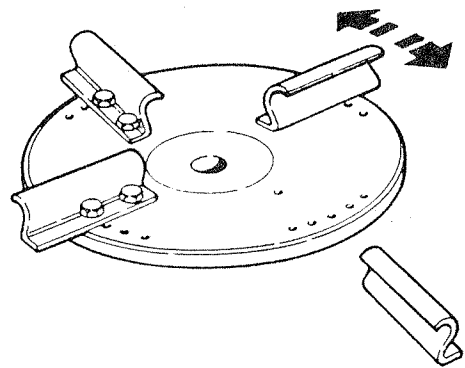

FIG. 6

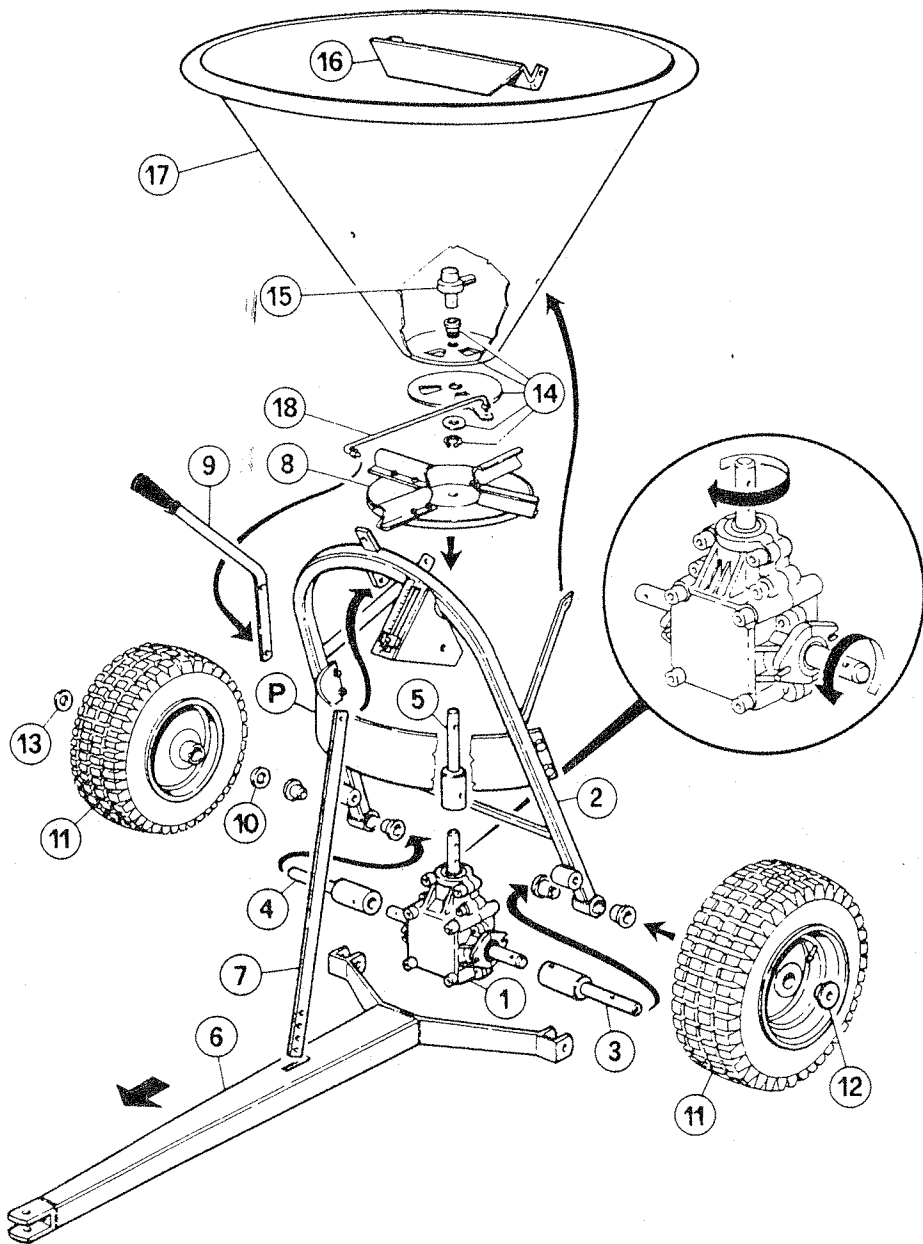

FIG. 7

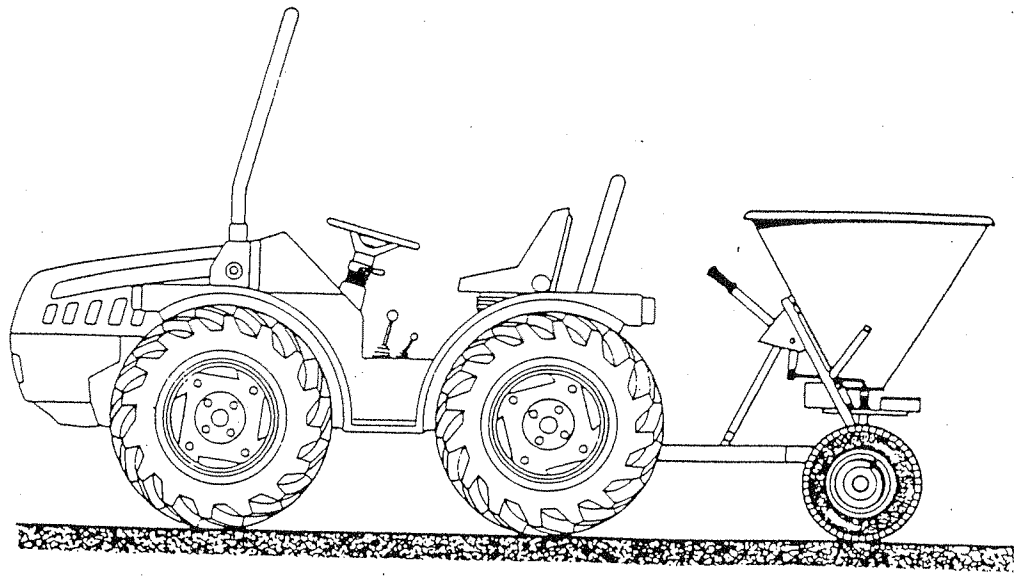

FIG. 8

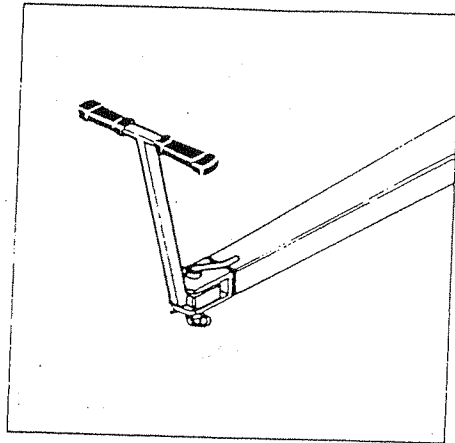
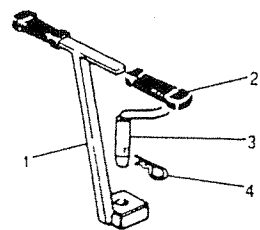

FIG. 9

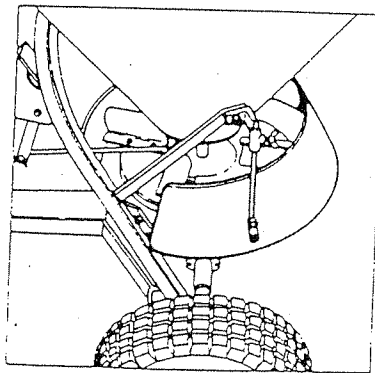
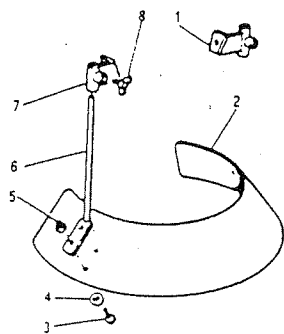

FIG. 10

SPREADING TABLE FOR FERTILIZER SPREADERS SERIES FSP

FERTILIZER TYPE	SPREADING RANGE (yards)	MPH/h	Lbs/acre OF FERTILIZER TO BE SPREAD WITH ENGINE R.P.M. AS IN COLUMN Mph/h												
			OPENING												
			1,5	2	2,5	3	3,5	4	4,5	5	5,5	6	6,5	7	
COARSE-GRAINED FERTILIZERS	15,5	2,5	201	335	616	1016	1298	1601	1940	2343	2578	2899	3176	3573	
		3,5	95	139	247	415	517	642	791	937	1030	1164	1294	1452	
		5	52	70	129	205	260	321	393	473	525	602	662	745	
		6	35	54	86	139	176	219	260	324	343	401	433	492	
		7,5	21	35	64	107	134	171	201	241	259	299	347	375	
MEDIUM-GRAINED FERTILIZERS	12	2,5		467	799	1141	1459	1808	2014	2341	2582	2827	2990	3288	
		3,5		176	330	468	599	740	827	947	1041	1143	1204	1334	
		5		105	171	236	303	376	418	479	526	582	610	672	
		6		73	113	163	199	253	286	326	355	401	415	457	
		7,5		54	82	116	155	189	207	246	268	295	312	341	
FINE-GRAINED FERTILIZERS	9	2,5	177	289	491	558	1066	1344	1575	1896	2134	2451	2658	2959	
		3,5	85	122	204	341	441	552	649	773	866	1001	1086	1188	
		5	46	59	108	178	225	281	325	397	442	500	542	604	
		6	29	41	94	122	153	194	221	264	298	341	370	405	
		7,5	17	30	53	87	114	137	169	200	235	257	283	299	
MEDIUM-CRYSTAL FERTILIZERS	6,5	2,5	335	553	1021	1655	2046	2623	3065	3652	4088	4537	4975	5481	
		3,5	117	222	435	670	827	1068	1237	1466	1643	1826	2000	2203	
		5	69	113	211	334	422	541	623	740	832	920	1003	1107	
		6	45	77	142	226	284	369	421	497	554	615	674	738	
		7,5	30	54	102	173	211	278	322	368	414	461	503	557	
CALCIUM CYANAMIDE AND SIMILAR	7,5	2,5	278	760	1120	1658	2047	1869	2907	3391	4348				
		3,5	111	304	459	680	820	1007	1174	1361	1529				
		5	59	151	232	301	412	501	592	682	765				
		6	37	101	150	221	276	337	393	455	509				
		7,5	26	79	113	169	207	254	293	341	381				
AMMONIUM SULPHATE	7,5	2,5	144	573	937	1410	1804	2229	2643	3103	3401	3819	4095	4583	
		3,5	62	227	378	565	726	898	1054	1244	1366	1533	1643	1844	
		5	29	116	191	285	367	450	526	624	680	785	820	922	
		6	23	74	124	192	244	299	353	424	458	515	551	794	
		7,5	15	59	95	145	182	225	266	321	341	383	416	459	
THOMAS MEAL	4,5	2,5					2294	5106	6762	7024					
		3,5					580	1294	1708	1760					
		5					294	544	587	881					
		6					198	433	301	591					

SPREADING TABLE FOR SEEDS SPREADERS SERIES FSP

SEEDS	SPREADING RANGE (yards)	MPH/h	Lbs/acre OF SEEDS TO BE SPREAD WITH ENGINE R.P.M. AS IN COLUMN Mph/h						
			OPENING						
			1	1,5	2	2,5	3	3,5	4
WHEAT	12	1			273	442	604	740	
		2,5			109	176	241	316	
		5			54	87	120	158	
		7,5			36	58	79	105	
		10			26	43	60	79	
OAT	6,5	1		210	347	517	693		
		2,5		82	138	206	277		
		5		41	69	103	137		
		7,5		27	45	69	92		
		10		20	34	50	69		
RYE	12	1			352	549	752	914	
		2,5			139	216	300	366	
		5			72	109	149	183	
		7,5			45	73	99	121	
		10			35	55	77	91	
BARLEY	9	1				362	439	607	747
		2,5				144	176	244	298
		5				71	87	120	148
		7,5				46	57	81	98
		10				36	44	59	73
RYE GRASS	4	1	50	142	299				
		2,5	20	57	120				
		5	11	29	61				
		7,5	7	20	40				
		10	5	14	30				
TURNIP SEEDS	5	1	38	214	426				
		2,5	16	86	171				
		5	8	42	86				
		7,5	6	29	57				
		10	4	21	42				
RED CLOVER	5	1	57	196	481				
		2,5	22	79	194				
		5	11	39	96				
		7,5	7	26	65				
		10	6	21	48				

SPREADING TABLE FOR FERTILIZER SPREADERS SERIES FSP

FERTILIZER TYPE	SPREADING RANGE (metres)	km/h	kg/ha OF SEEDS TO BE SPREAD WITH ENGINE R.P.M. AS IN COLUMN km/h											
			OPENING											
			1,5	2	2,5	3	3,5	4	4,5	5	5,5	6	6,5	7
COARSE-GRAINED FERTILIZERS	14	4	225	375	691	1139	1455	1795	2175	2626	2890	3250	3560	4005
		6	106	156	277	465	580	720	887	1050	1155	1305	1450	1628
		8	58	78	145	230	292	360	441	530	588	675	742	835
		10	39	60	96	156	197	245	292	363	385	450	485	552
		12	23	39	72	120	150	192	225	270	290	335	389	420
MEDIUM-GRAINED FERTILIZERS	11	4		523	896	1279	1635	2027	2258	2624	2894	3169	3352	3686
		6		197	370	525	671	830	927	1062	1167	1281	1350	1495
		8		118	192	265	340	422	469	537	590	652	684	753
		10		82	127	183	223	284	321	365	398	449	465	512
		12		60	92	130	174	212	232	276	300	331	350	382
FINE-GRAINED FERTILIZERS	8	4	198	324	550	626	1195	1507	1766	2125	2392	2748	2980	3317
		6	95	137	229	382	494	619	727	866	971	1122	1217	1332
		8	52	66	121	200	252	315	364	445	496	561	608	677
		10	33	46	105	137	172	217	248	296	334	382	415	454
		12	19	34	59	98	128	154	189	224	263	288	317	335
MEDIUM-CRYSTAL FERTILIZERS	6	4	375	620	1144	1855	2294	2940	3436	4094	4583	5086	5577	6144
		6	131	249	488	751	927	1197	1387	1643	1842	2047	2242	2470
		8	77	127	237	374	473	607	698	829	933	1031	1124	1241
		10	50	86	159	253	318	414	472	557	621	689	755	827
		12	34	61	114	194	236	312	361	413	464	517	564	624
CALCIUM CYANAMIDE AND SIMILAR	7	4	312	852	1255	1859	2295	2095	3259	3801	4874			
		6	124	341	515	762	919	1129	1316	1526	1714			
		8	66	169	260	337	462	562	664	764	858			
		10	42	113	168	248	309	378	441	510	571			
		12	29	89	127	189	232	285	328	382	427			
AMMONIUM SULPHATE	7	4	161	642	1050	1581	2022	2499	2963	3478	3812	4281	4590	5138
		6	69	254	424	633	814	1007	1182	1395	1531	1718	1842	2067
		8	32	130	214	319	411	504	590	699	762	880	919	1033
		10	26	83	139	215	274	335	396	475	513	577	618	890
		12	17	66	107	162	204	252	298	360	382	429	466	515
THOMAS MEAL	4	4					2571	5724	7580	7874				
		6					650	1451	1915	1973				
		8					330	610	658	988				

SPREADING TABLE FOR SEEDS SPREADERS SERIES FSP

	SPREADING RANGE (metres)	km/h	kg/ha OF SEEDS TO BE SPREAD WITH ENGINE R.P.M. AS IN COLUMN km/h						
			OPENING						
			1	1,5	2	2,5	3	3,5	4
WHEAT	11	1,5			306	495	677	830	
		4			122	197	270	354	
		8			81	98	135	177	
		12			40	65	89	118	
		16			29	48	67	88	
OAT	6	1,5		235	389	580	777		
		4		92	155	231	310		
		8		46	77	115	154		
		12		30	51	77	103		
		16		22	38	56	77		
RYE	11	1,5			395	615	843	1025	
		4			156	242	336	410	
		8			81	122	167	205	
		12			51	82	111	136	
		16			39	62	86	102	
BARLEY	8	1,5				406	492	680	837
		4				161	197	273	334
		8				80	97	135	166
		12				52	64	91	110
		16				40	49	66	82
RYE GRASS	3,5	1,5	56	159	335				
		4	22	64	134				
		8	12	33	68				
		12	8	22	45				
		16	6	16	34				
TURNIP SEEDS	4,5	1,5	43	240	478				
		4	18	96	192				
		8	9	47	96				
		12	7	32	64				
		16	4	24	47				
RED CLOVER	4,5	1,5	64	220	539				
		4	25	88	217				
		8	12	44	108				
		12	8	29	73				
		16	7	23	54				

SPARE PARTS LIST

FSP 100 / 150

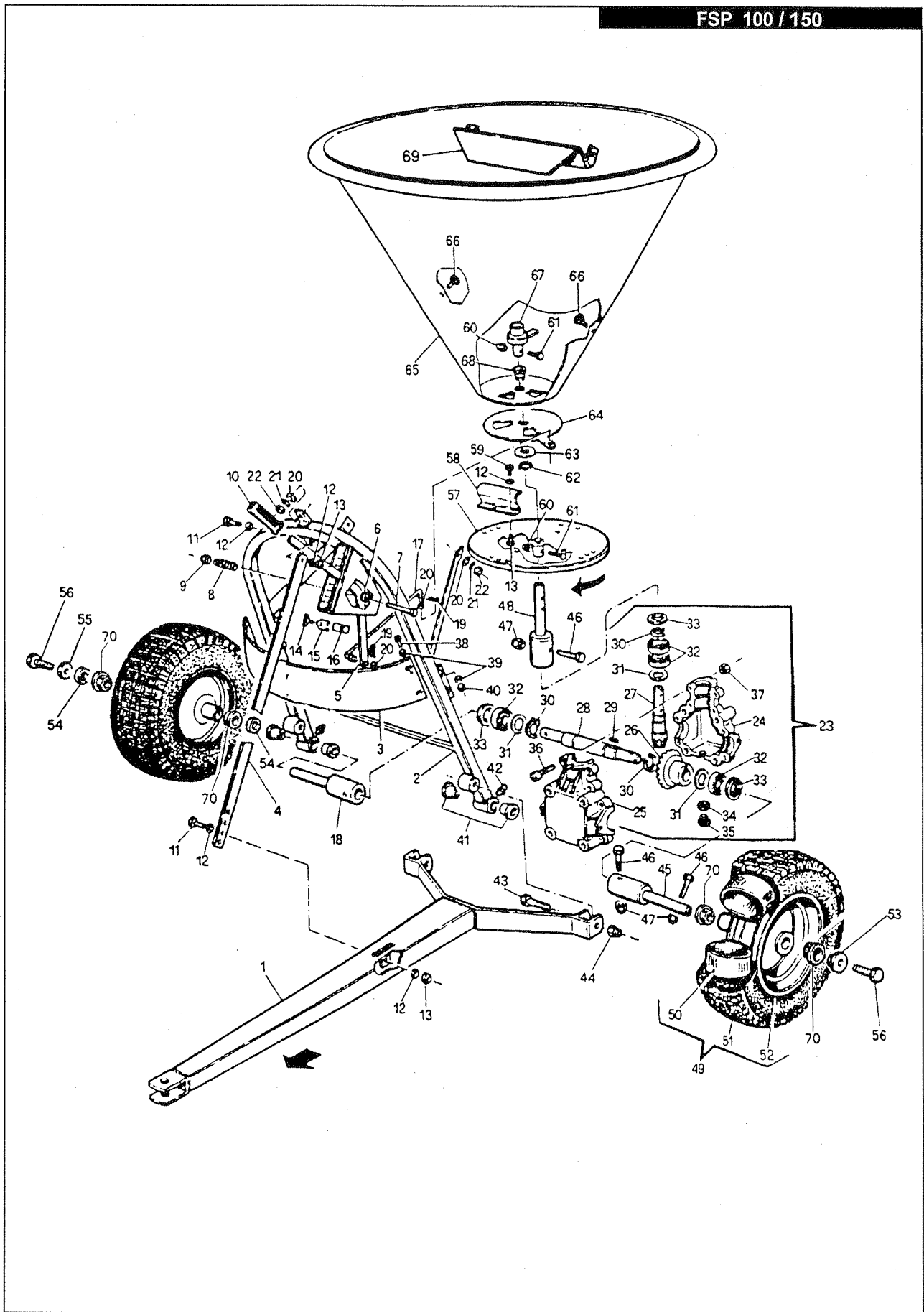
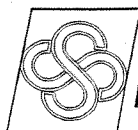

TABLE NO.940.007

FSP 100/150

ITEM	Q.ty	PART NO	DESCRIPTION	ITEM	Q.ty	PART NO	DESCRIPTION
1	1	400.174	DRAWBAR	37	8	600.037	NUT
2	1	400.175	FRAME	38	4	610.451	SCREW
3	1	400.176	GUARD	39	8	600.514	WASHER
4	1	400.177	TIE-ROD	40	4	600.532	NUT
5	1	400.178	LEVER	41	4	400.182	BUSHING
6	1	400.049	WASHER	42	2	600.913	GREASE NIPPLE
7	1	600.528	SCREW	43	2	610.452	SCREW
8	1	400.048	SPRING	44	2	600.916	NUT
9	1	600.554	NUT	45	1	400.183	SHAFT
10	1	600.450	HANDLE	46	4	610.453	SCREW
11	2	610.447	SCREW	47	4	610.454	NUT
12	8	600.115	WASHER	48	1	400.184	SHAFT
13	6	600.553	NUT	49	2	610.455	TIRE ASSY
14	1	600.184	SCREW	50	2	610.456	TUBE
15	1	400.021	INDICATOR	51	2	610.457	TIRE
16	1	400.001	LOCKING DEVICE	52	2	610.465	RIM
17	1	400.179	TIE-ROD	53	1	400.192	WASHER
18	1	400.180	LH SHAFT	54	2	610.459	WASHER
19	2	600.113	PIN	55	1	610.460	WASHER
20	5	600.322	WASHER	56	2	610.461	SCREW
21	3	600.938	WASHER	57	1	400.185	SPINNER
22	3	600.939	NUT	58	4	400.186	FIN
23	1	610.440	GEAR-BOX	59	4	600.060	SCREW
24	1	610.441	SEMI-GEARBOX	60	1	610.462	NUT
25	1	610.442	SEMI GEARBOX	61	1	610.463	SCREW
26	1	610.443	CROWN	62	1	600.110	SNAP RING
27	1	610.444	PINION	63	1	400.063	WASHER
28	1	610.445	SHAFT	64	1	400.059	DISC
29	1	610.446	TAB	65	1	400.187	FSP 100 HOPPER
30	3	600.316	SNAP RING	65	1	400.188	FSP 150 HOPPER
31	3	400.181	SPACER	66	3	610.464	SCREW
32	4	600.320	BEARING	67	1	400.189	AGITATOR
33	3	610.448	OIL RETAINER	68	1	400.190	BUSHING
34	1	610.449	GASKET	69	1	400.191	PROTECTION
35	1	610.450	CAP	70	4	400.244	NYLON BUSHING
36	8	600.312	SCREW				



AGRICULTURAL MACHINERY
sitrex[®] s.r.l.

Zona Industriale-Viale Grecia, 8
06018 TRESTINA-(Perugia)-ITALY
Tel. +39.075.8540021-Telefax +39.075.8540523
e-mail: sitrex@sitrex.it www.sitrex.com

