

**WALTON®**

OMUS01RCS-0203W

# RCS 8-10-12 CARTED HAY RAKE

OPERATOR'S MANUAL

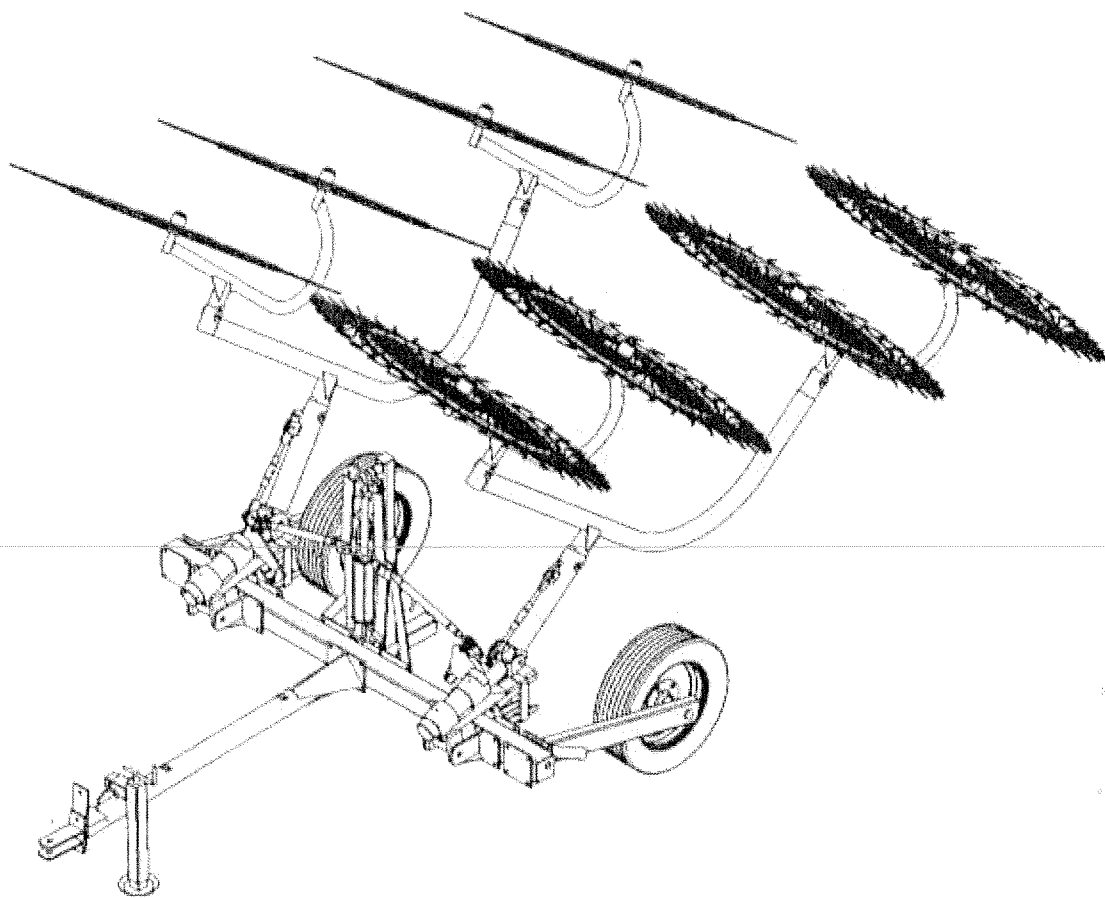

**WALTON<sup>®</sup>**

---

# **RICHEY EQUIPMENT INC.**

P.O. BOX 609  
WHITE PINE, TN 37890 U.S.A.  
PHONE 800-207-2086  
FAX 888-696-7637

---

## **IMPORTANT NOTICE**

**LEFT**

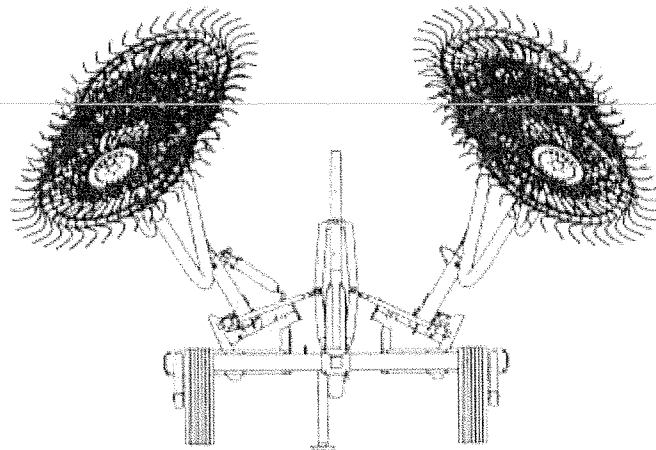



**RIGHT**

**REAR**

Determine the right or left side of the machine by viewing it from the rear.

---

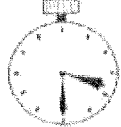
TABLE OF CONTENTS .....	1
SAFETY MESSAGES .....	2-6
SAFETY , I.D., MODEL DECALS .....	7
ASSEMBLY .....	8-21
RAKE ADJUSTEMENTS .....	22
HOOKUP, TRANSPORT, UNHOOKING .....	23-25
RAKING .....	26-29
LUBRICATION AND MAINTENANCE .....	30-31
RAKES SPECIFICATIONS .....	32
RECOMMENDED TORQUE VALUES .....	33

	Assembly time: 3 h	
---	--------------------	---

### BEWARE OF SAFETY INFORMATION

This is the safety-alert symbol. This symbol placed on your machine or in the manual is used to alert you to the potential for personal injury or death.

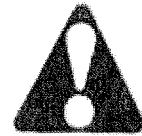

### UNDERSTAND SIGNAL WORDS

A signal word "DANGER", "WARNING", or "CAUTION" is used with the safety-alert symbol.

Safety signs with signal word "DANGER", "WARNING", or "CAUTION" are located near specific hazards.

**DANGER** - Imminent hazards which, if not avoided, will result in serious personal injury or death.

**WARNING** - Potential hazards or unsafe practices which, if not avoided, could result in serious personal injury or death.

**CAUTIONS** - Potential hazards or unsafe practices which, if not avoided, could result in minor personal injury or product or property damage.

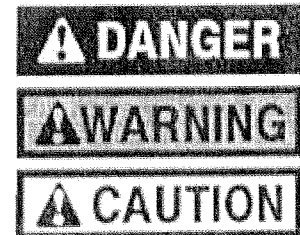

### READ MANUALS

Do not operate the machine unless the instructions in the following manuals have been carefully read and understood:

- \* The Wheel Rake Operator's Manual
- \* Tractor Operator's Manual

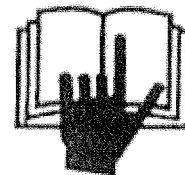

### FOLLOW INSTRUCTIONS

Carefully read and understand all safety messages in this manual and on your machine safety decals.

Safety decals located on your machine contain important information that will help you operate your equipment safely. Keep safety decals in good condition. Replace missing or damaged safety decals.

Allow only responsible, properly instructed individuals to operate the machine. Carefully supervise inexperienced operators.

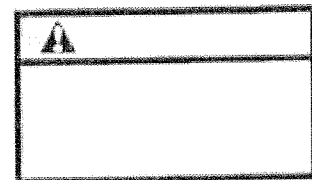
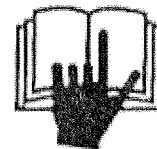

**PERSONAL PROTECTION**

Wear required personal protective equipment.

Wear close fitting clothing and confine long hair.

Avoid wearing jewellery, such as rings, wrist watches, necklaces, or bracelets.

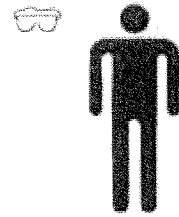
**KEEP MACHINE IN GOOD CONDITION**

Be sure the machine is in good operating condition and that all safety devices are installed and are functioning properly.

Visually inspect the machine daily before using the machine.

Make no modifications to your equipment unless specifically recommended or requested by WALTON CO.

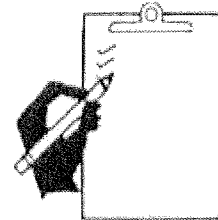
**REDUCE SPEED WHEN TOWING LOADS**

Be sure that the tractor is large enough to have adequate braking and steering control when towing implements that do not have brakes.

Reduce speed if towed load without brakes weighs more than the tractor.

Use additional caution when towing loads under adverse surface conditions, when turning, and on inclines.

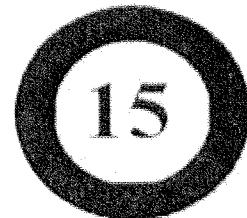

m.p.h.

**KEEP SPECTATORS AWAY FROM MACHINE**

Keep all spectators and other workers away from the machine and work area while in operation or when raising and lowering the rake arms.

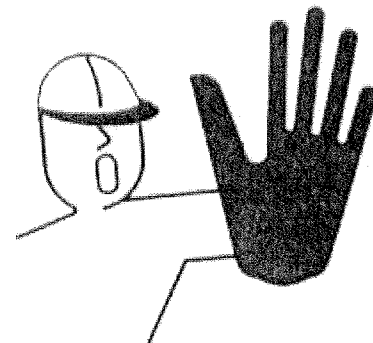

---

**NO RIDERS**

Be sure the tractor operator is the only person riding the tractor. Do not allow riders on the machine.

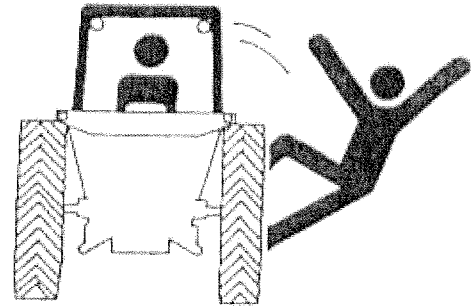

---

**CHECK THE FIELD**

Be alert and use extreme caution when operating on hillsides or near ditches, gullies, holes, or obstructions where rollover could occur.

Watch out for and avoid any object that might interfere with the proper operation of the machine. (i.e. stones and limbs).

---

**AVOID HIGH PRESSURE LEAKS**

Relieve all pressure in the system before disconnecting the lines, hoses, or performing other work. Make sure all connections are tight and that hoses and lines are in good condition before applying pressure to the system.

Any fluid under pressure can penetrate the skin and cause personal injury, blindness or death. Fluid leaks, under pressure, may not be visible.

Use a piece of cardboard or wood to find leaks; never use your bare hand. Wear safety glasses for eye protection. If any fluid is injected into the skin, it must be surgically removed within a few hours by a doctor familiar with this type of injury.

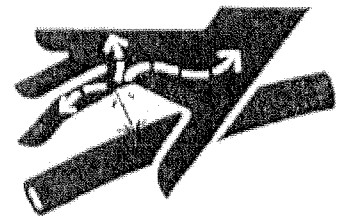

---

**AVOID TIRE EXPLOSION**

Tire explosion can result if the following procedures are not followed:

- Maintain correct tire pressure. Do not inflate tire above recommended pressure.
- Check for low tire pressure. Inflate to recommended pressure.
- Replace any wheel with cuts, bubbles, or damaged rims.
- Do not weld or heat wheel assembly. Heating will increase tire pressure.

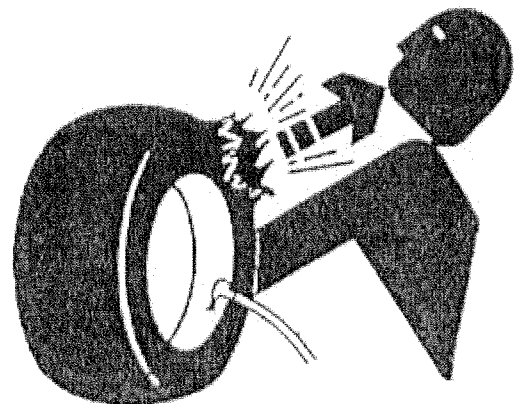

### DRIVING ON PUBLIC ROADS

Install safety chains (A) which block the rake arms

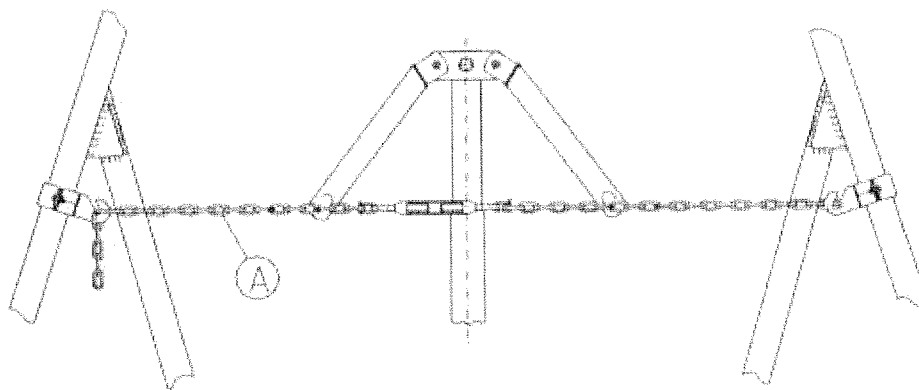

Safety chain will reduce the risk of injury due to collision or loss of implement control if the drawn implement becomes unhitched from drawbar.

Provide enough slack in the chain to permit turning.

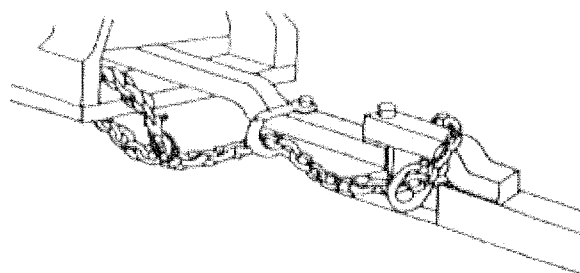

Install the cylinder safety stop (B) to prevent the rake arms from dropping during transport

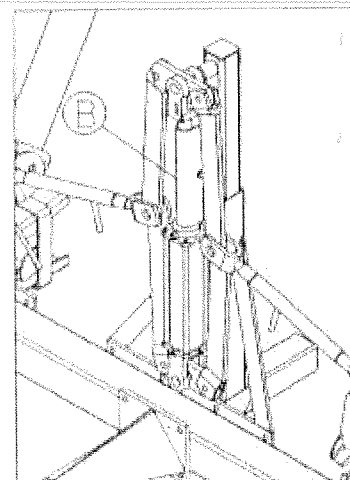
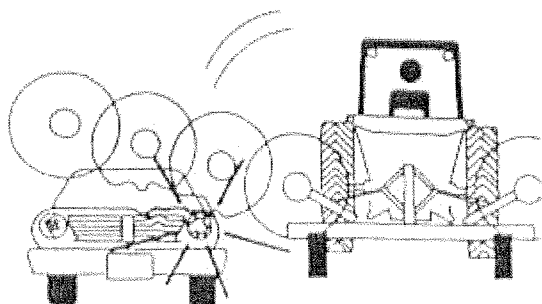

**WORKING ON THE RAKE**

Before working on or near rake for any reason including servicing, lubricating, cleaning or inspecting rake:

1. Disengage power to the tractor's ground drive.
2. Set park brake.
3. Shut off the tractor engine and remove the key.
4. Install cylinder safety stop before working under rake arms or unhitching rake from tractor when the baskets are in the raised position (B).
5. Install the safety chains (A) + (C).

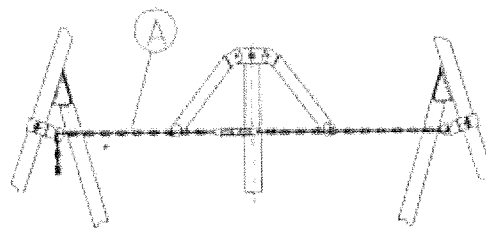
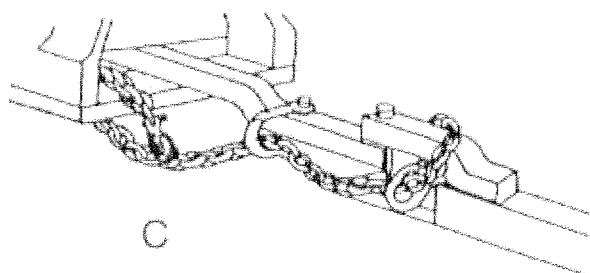
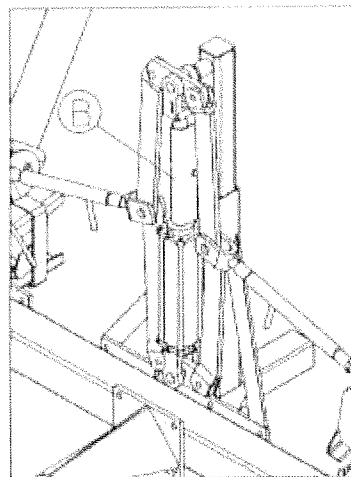

All machinery is particularly dangerous to children and persons that are unfamiliar with its general operation. The WALTON CO. strongly recommends that no person without a thorough understanding of how the WALTON wheel rakes operate be permitted to operate the machine. The machine should be operated only by responsible persons who have thoroughly read the operator's manual and are informed about the machine's use and are delegated to do so.

Prior to operating the rake, be sure to read and understand this operator's manual. If there is any portion you do not understand, or any phase of the machine's operation you do not understand, be sure to contact your local WALTON dealer or distributor.

Use this manual thoroughly to familiarize yourself with the machine.



## INSPECTING SAFETY DECALS

Safety decals located on your machine contain important and useful information that will help you operate your equipment safely. To assure that all decals remain in place and in good condition, follow the instructions given below.

- Keep decals clean. Use soap and water, not mineral spirits, abrasive cleaners, or other similar cleaners, that will damage the decal.
- Replace any damaged or missing decals. When attaching decals, surface temperature of the metal must be at least 40° F (5°C). The metal must also be clean and dry.
- When replacing a machine component with a decal attached, replace the decal also.
- Replacement decals can be purchased from your Walton equipment dealer.

## DECALS LOCATION

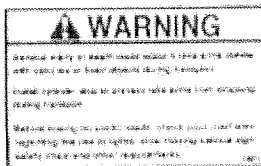

1) ONE PIECE

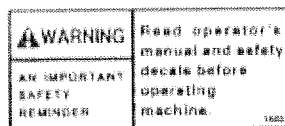

2) ONE PIECE

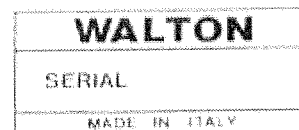

3) ONE PIECE

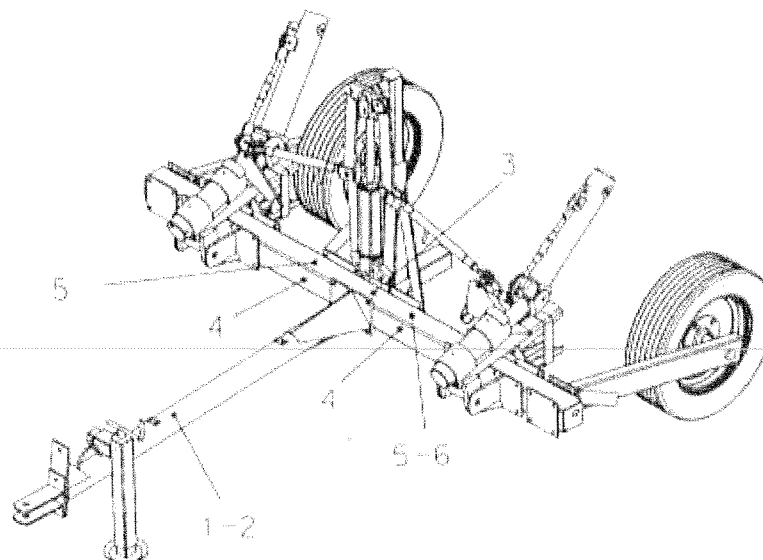

4) TWO PIECES



5) TWO PIECES

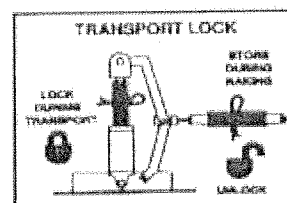

6) ONE PIECE

### ASSEMBLY

IMPLEMENTS.  
IMPLEMENT IS SHIPPED DISASSEMBLED IN WOODEN CRATES.  
FASTENERS ARE METRIC. USE ONLY METRIC TOOLS FOR METRIC FASTENERS. REMOVE PARTS FROM CRATE AND LAY OUT IN ASSEMBLY ORDER. SELECT AN AREA THAT HAS ADEQUATE SPACE FOR PARTS LAYOUT AND MACHINE ASSEMBLY.

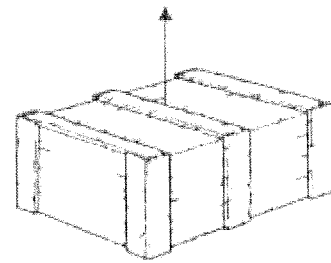

### INSTALL TONGUE TO REAR FRAME

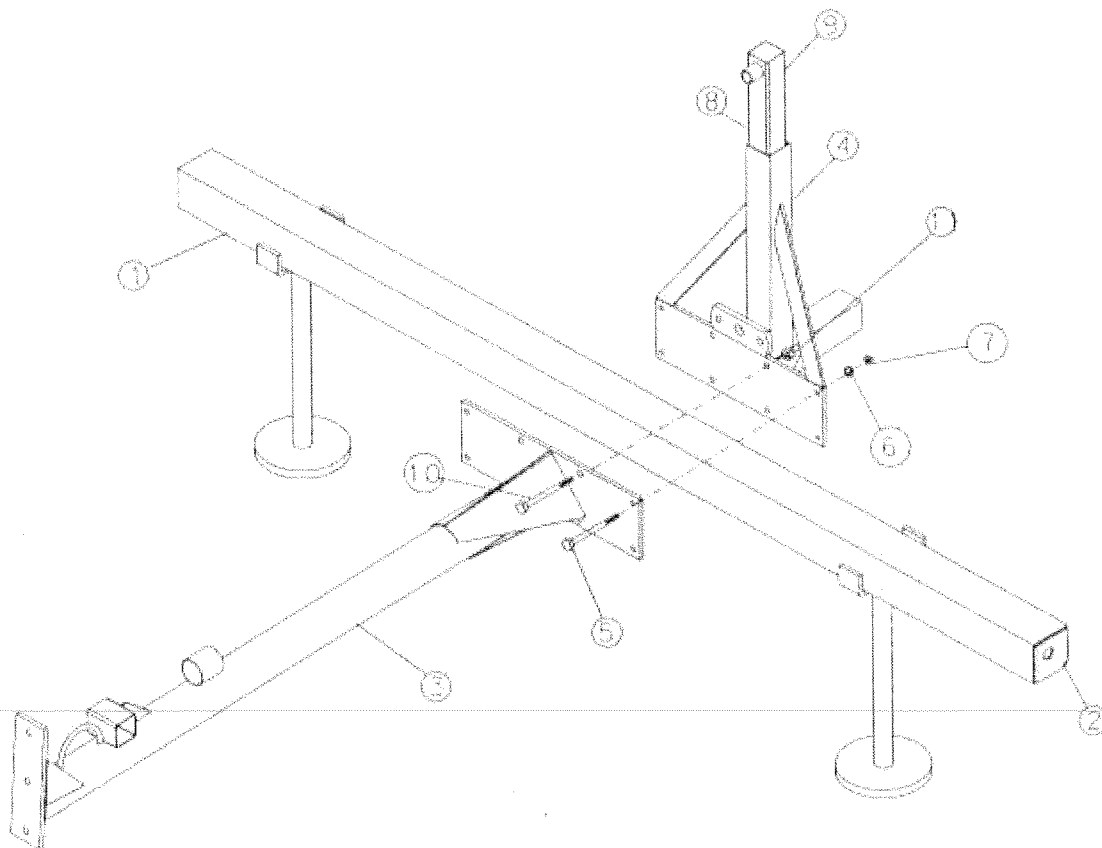

SUPPORT REAR FRAME (1) ON ASSEMBLY STANDS. MAKE SURE FRAME (1) IS POSITIONED SO DRAIN HOLE (2) IS TOWARD THE BOTTOM.

MARK THE EXACT CENTER OF REAR FRAME. USE MARK FOR TONGUE INSTALLATION.

INSTALL TONGUE (3) AND CYLINDER SUPPORT (4) IN THE CENTER OF REAR FRAME. FASTEN WITH FOUR M14x140 CAP SCREWS (5), FOUR M12x140 (10), LOCK WASHERS (6), AND NUTS (7)(11).

APPLY MULTIPURPOSE GREASE TO TUBE (9).

INSTALL TUBE (9) INTO SUPPORT (4) WITH LONGER SPACER (8) TOWARD THE FRONT OF MACHINE.

## INSTALL WHEELS AND JACKSTAND

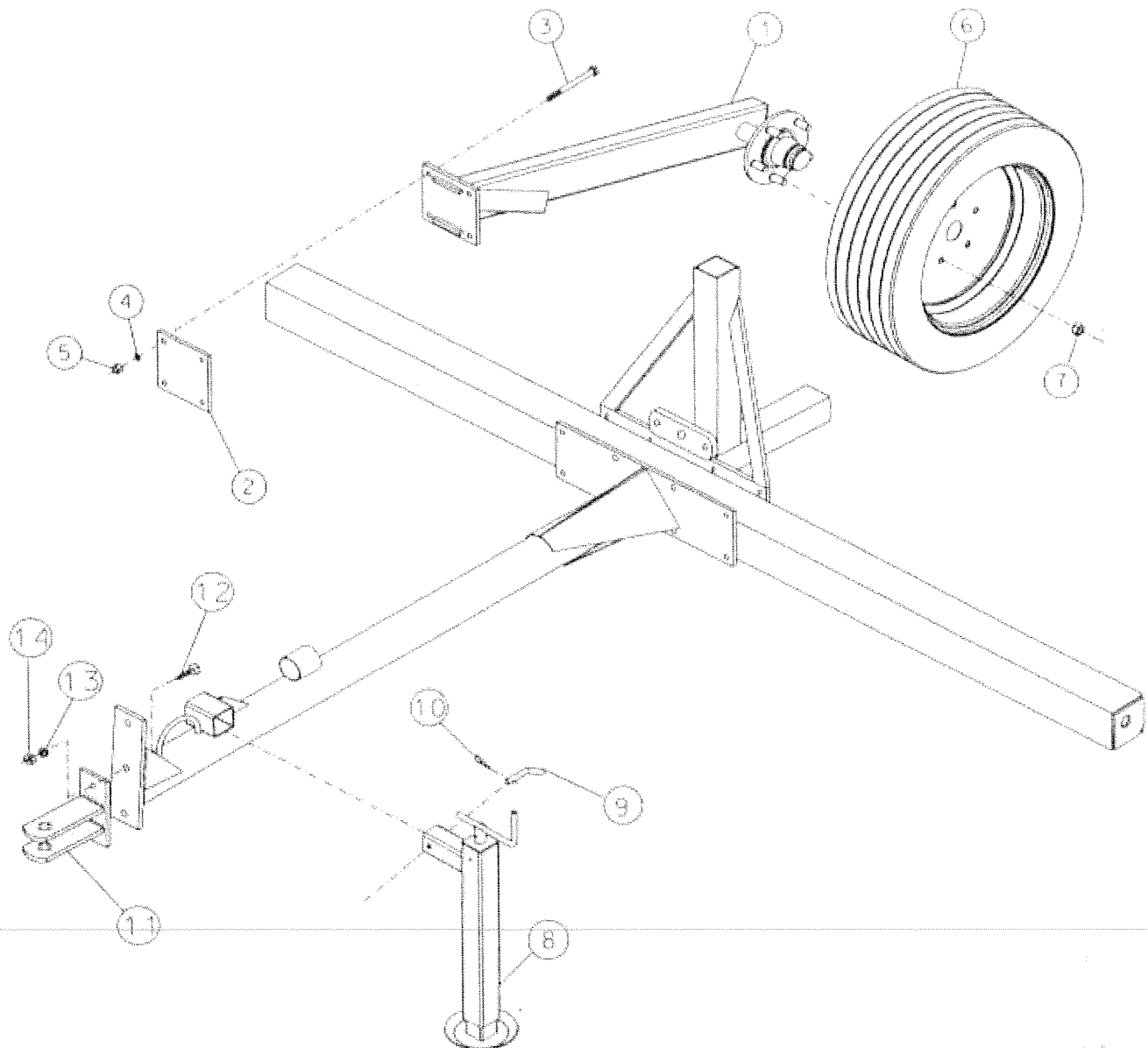

INSTALL WHEEL SUPPORT (1) AND PLATE (2) TO FRAME. FASTEN WITH FOUR M12x140 CAP SCREW (3) LOCK WASHERS (4) AND NUTS (5). INSTALL THE WHEEL (6) ON THE HUB AND FASTEN WITH FIVE M16 LUG NUTS (7). REPEAT PROCEDURE ON OPPOSITE SIDE.

INSTALL JACKSTAND (8). FASTEN WITH PIN (9) AND SPRING-LOCKING PIN (10).

INSTALL THE BRACKET ATTACHMENT TRACTOR (11) AND SECURE IT WITH TWO SCREW TE M16x40 (12) LOCK WASHERS (13) AND NUTS (14).

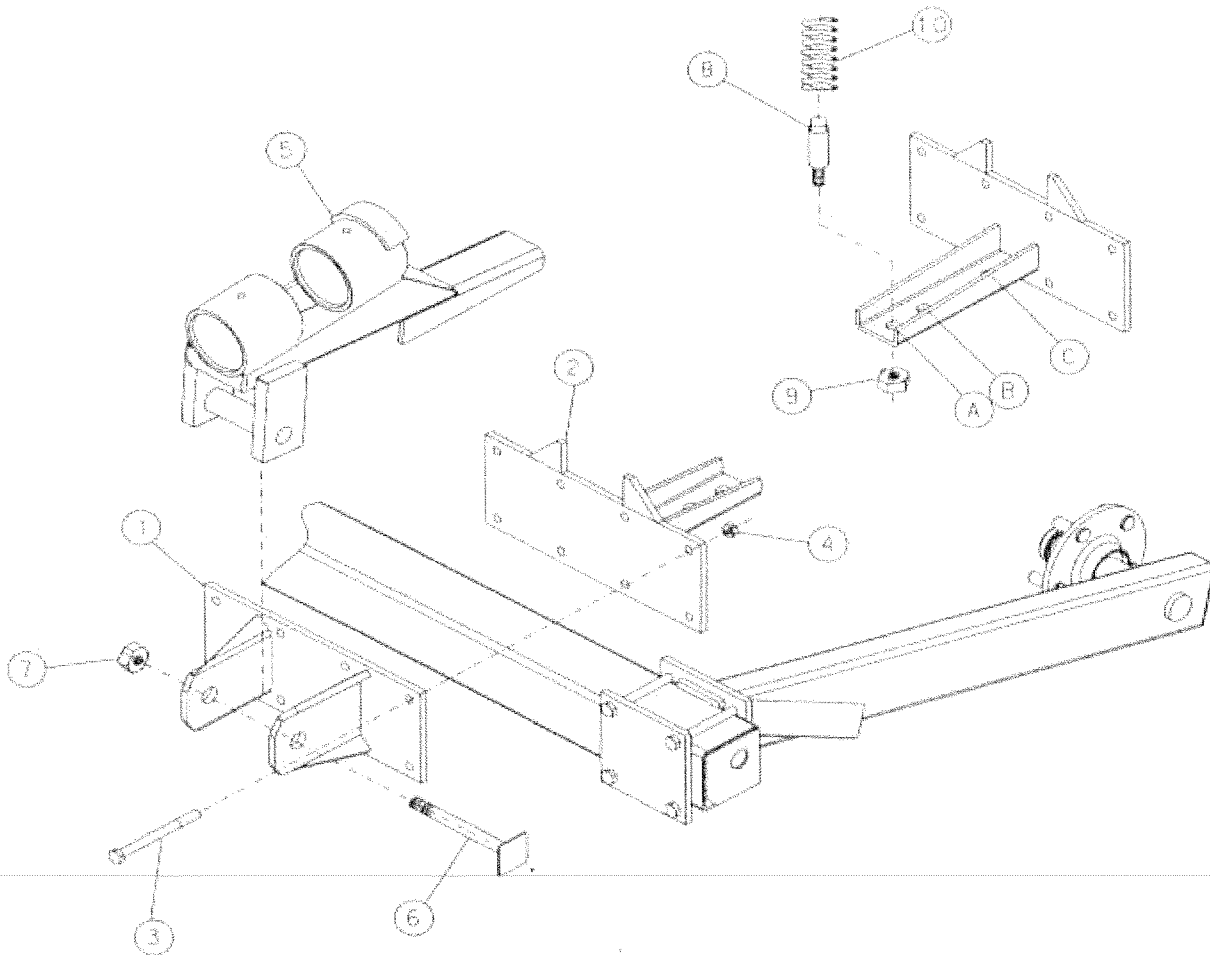
**INSTALL PIVOT HEAD ASSEMBLY**

INSTALL THE LEFT PIVOTING SUPPORT (1) AND THE SPRING SUPPORT (2) ON THE MAIN FRAME WITH EIGHT SCREWS TE M12x140 (3) AND NUTS (4). GREASE THE PIVOTING SURFACES. ASSEMBLY THE HEAD (5) IN THE PIVOTING SUPPORT (1) AND LOCK IT WITH M24 PIVOT (6), AND SELF LOCKING NUT M24 (7), BUT ASSURE THE FREE MOVEMENT OF THE PIVOTING.

INSTALL THE SPRING PIN (8) AND SPRING (10) ONTO SPRING SUPPORT. FASTEN WITH SELF LOCKING NUT. RCS 8 USE INNER HOLE (C), RCS10 USE CENTER HOLE (B), RCS 12 USE END HOLE (A). REPEAT FOR RIGHT SIDE

### INSTALL PIVOT HEAD ASSEMBLY

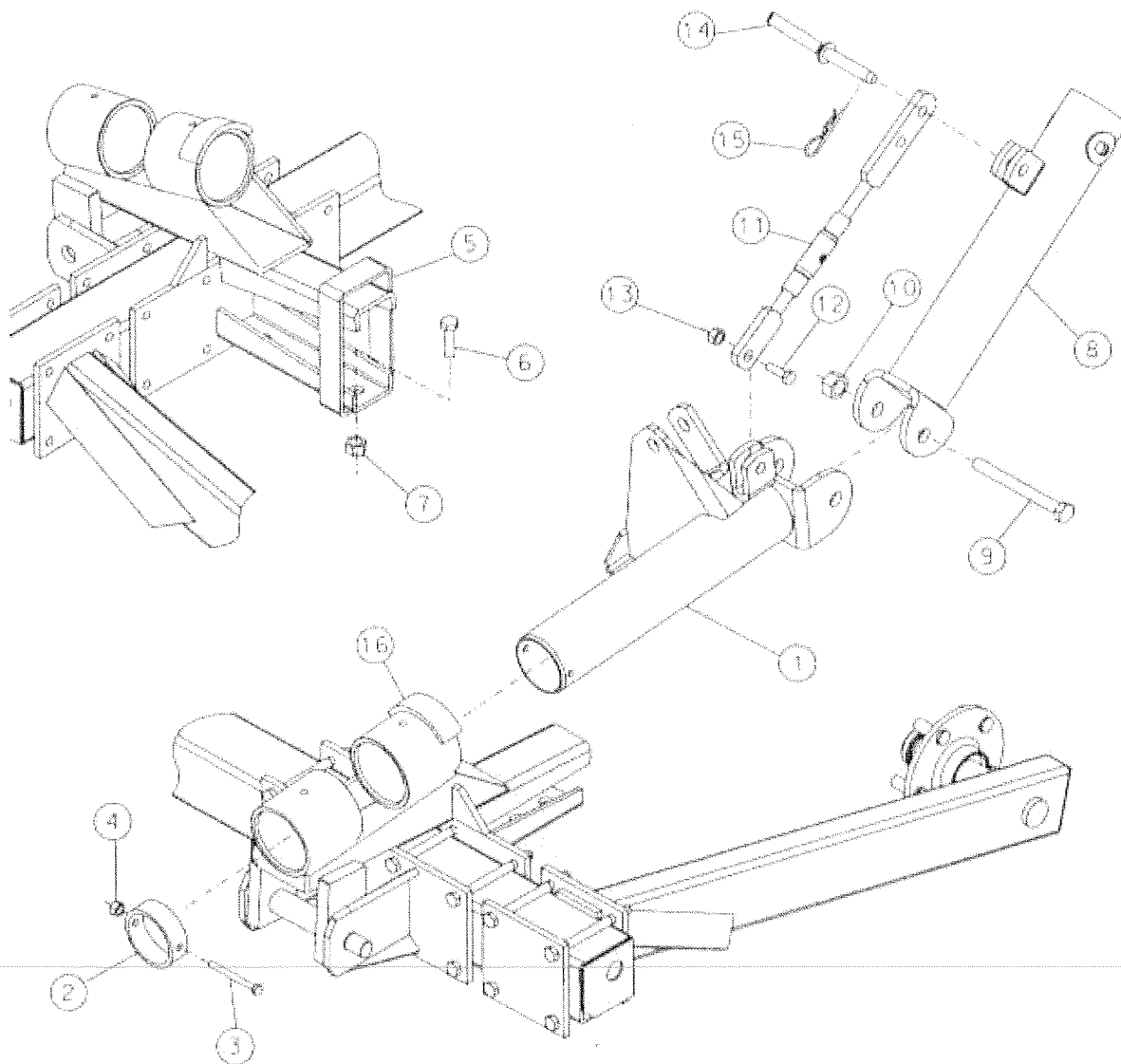

SLIDE LEFT PIVOT FOR FRAME (1) INTO THE PIVOTING HEAD (16) AS SHOWN IN THE PICTURE. INSTALL THE RING (2) AND LOCK IT WITH THE SCREW TE M10x120 (3) AND LOCKING NUT (4). INSTALL SAFETY LOOP (5) ON SPRING SUPPORT AT THE END HOLE AND LOCK IT WITH THE SCREW TE M18x50 (6) AND NUT (7). ASSEMBLE PIVOT MOVABLE (8) TO PIVOT FOR FRAME (1) WITH THE SCREW TE M20x150 (9) AND NUT (10). ASSEMBLE THE TURNBUCKLE (11) AS SHOWN IN THE PICTURE. USE THE SCREW TE M 16x55 (12) AND NUT (13). ASSEMBLE THE TURNBUCKLE TO THE PIVOT MOVABLE (8) WITH THE LOCK PIN (14) AND THE HAIR PIN "R" d=4 (15).

## INSTALL HYDRAULIC CYLINDER AND LIFT LINKS

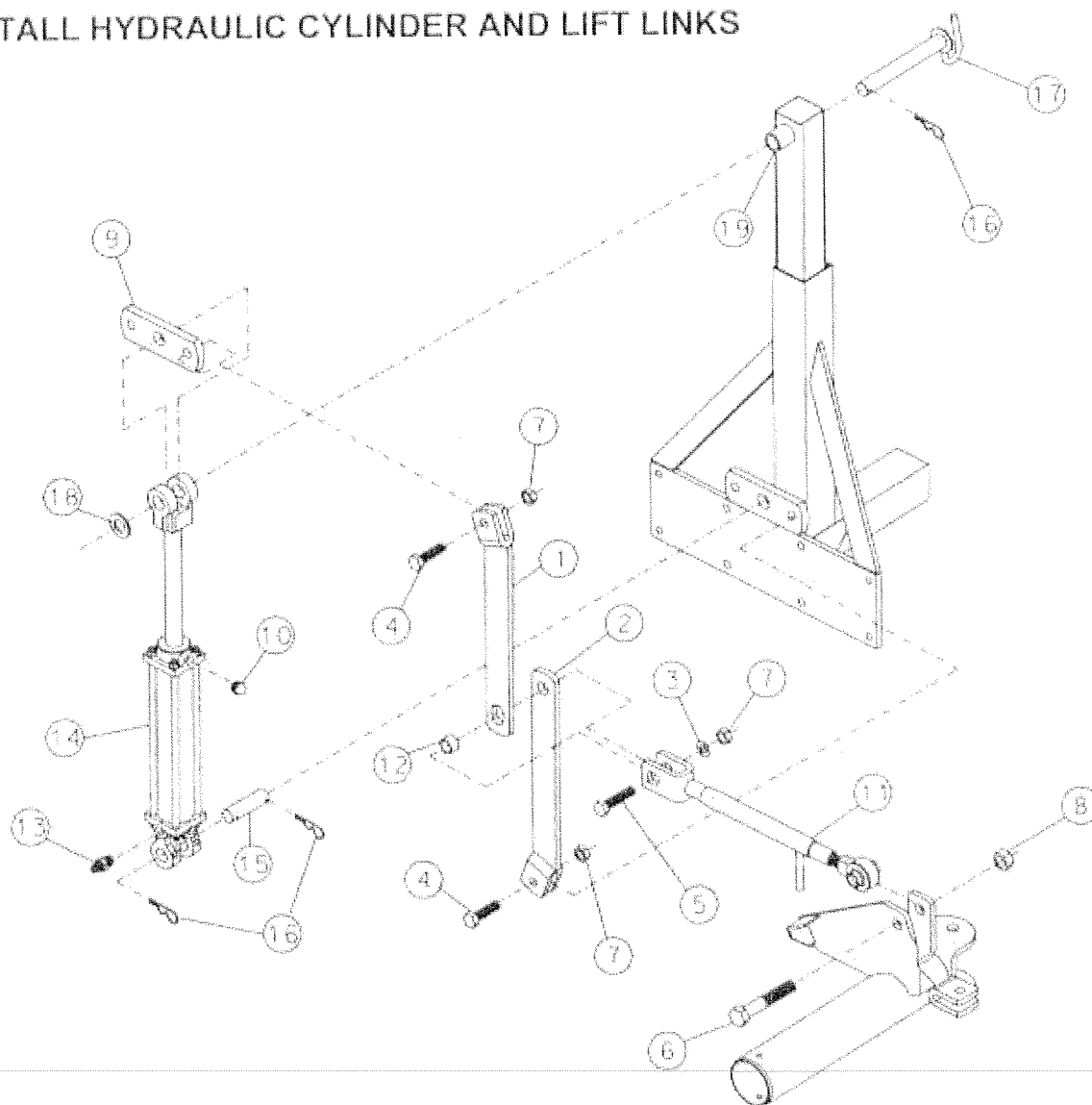

INSTALL BREATHER (10). WRAP PIPE THREADS OF THE FITTINGS WITH TEFLON TAPE BEFORE INSTALLING ON THE HYDRAULIC CYLINDER. INSTALL STRAIGHT FITTING (13) TO THE CYLINDER BARREL END. INSTALL EACH LOWER PANTOGRAPH ARM (2) TO THE CYLINDER STAND SUPPORT WITH M16x55 BOLT (4) AND SELF LOCKING NUT (7).

CONNECT THE UPPER PANTOGRAPH ARM (1) AND TURNBUCKLE (11) TO EACH LOWER PANTOGRAPH ARM. SECURE WITH M16x55 BOLT (5), BUSHING (12) WASHERS (3) AND SELF LOCKING NUT (7). CONNECT THE OTHER END OF TURNBUCKLE TO EACH PIVOT HEAD FRAMES AND SECURE WITH M20x90 BOLT (6) AND SELF LOCKING NUT (8). ATTACH THE BUTT END OF THE HYDRAULIC CYLINDER (14) TO THE CYLINDER STAND SUPPORT WITH CYLINDER PIN (15). SECURE WITH HAIR PINS (16). PASS THE PIVOT (17) THROUGH THE HOLE OF THE MEMBER (19), THE PLATE (9) AND THE FORK OF THE CYLINDER (14). FASTEN WITH WASHER (18) AND HAIR PIN (16). CONNECT THE PANTOGRAPH ARM (1) TO THE PLATE (9) WITH THE M16x55 SCREW (4) AND SELF LOCKING NUT (7).

## INSTALL RAKE WHEEL FRAMES

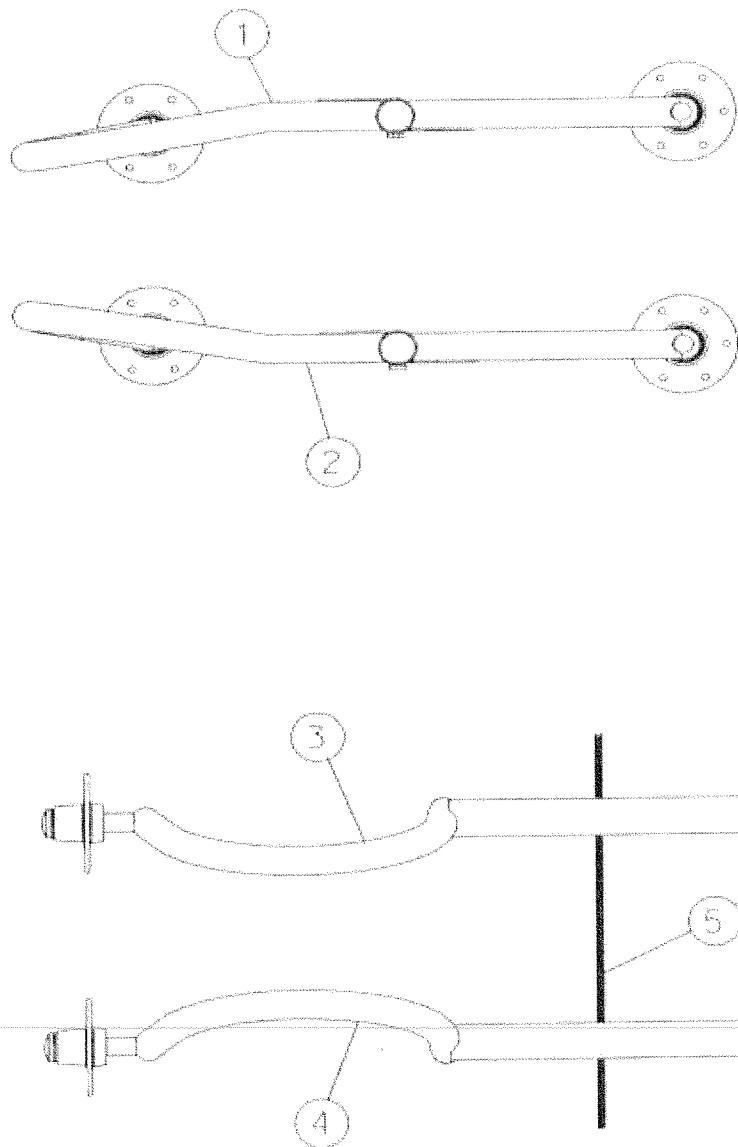

IDENTIFY LEFT-HAND WHEEL FRAMES (2) AND RIGHT-HAND WHEEL FRAMES (1).  
MAKE SURE FRAMES (1) AND (2) ARE INSTALLED WITH THE BEND IN THE UP POSITION.  
TO HELP IDENTIFY MIDDLE WHEEL FRAME , INSTALL ROD (5) THROUGH HOLES IN THE  
HORIZONTAL POSITION.

## INSTALL RAKE WHEEL FRAMES

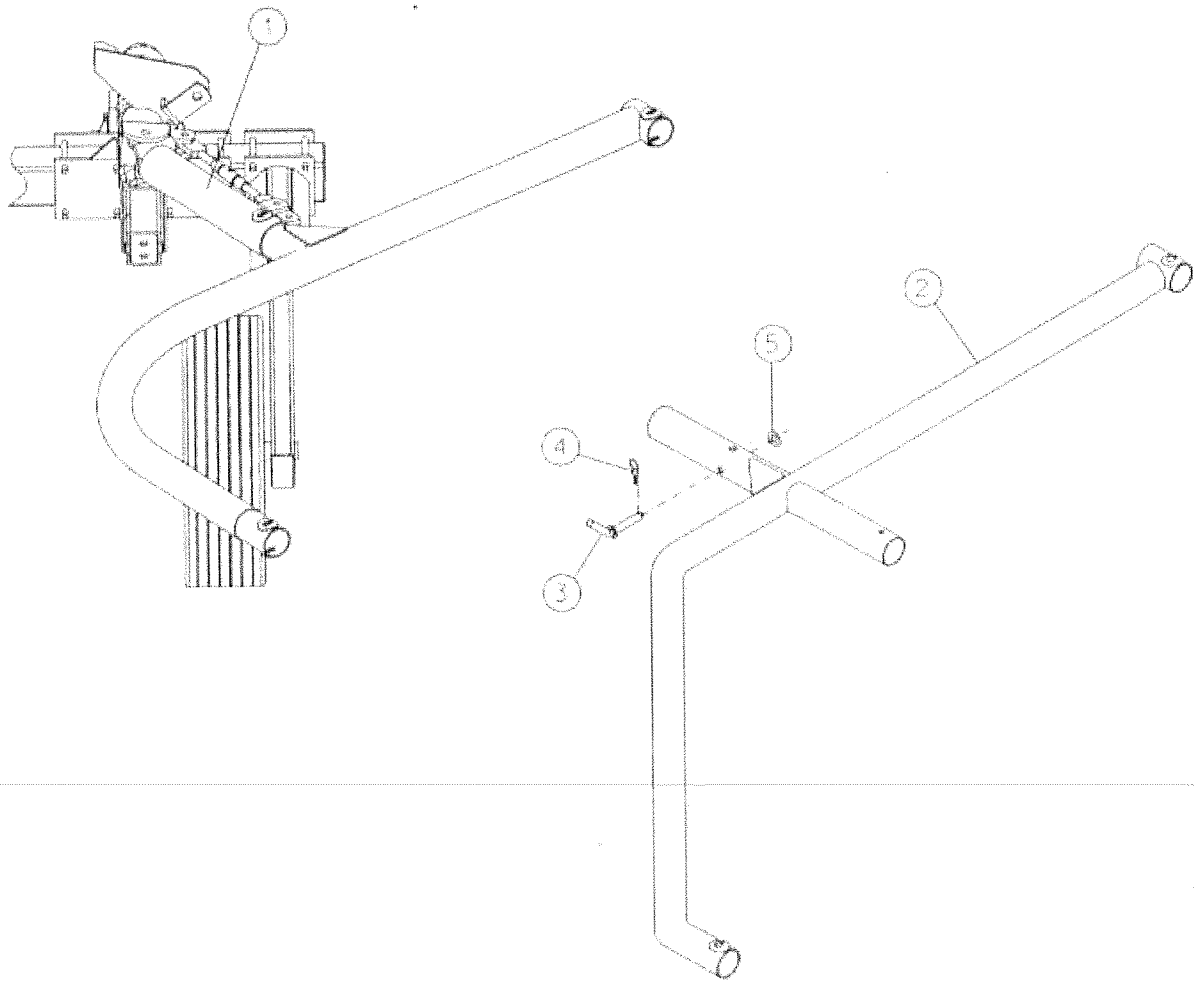

INSTALL RIGHT-HAND WHEEL MAIN FRAME (2) TO FRAME TUBE (1).  
FASTEN WITH M16 PIN (3), WASHER (5), AND SPRING PIN (4).



## INSTALL RAKE WHEEL FRAMES

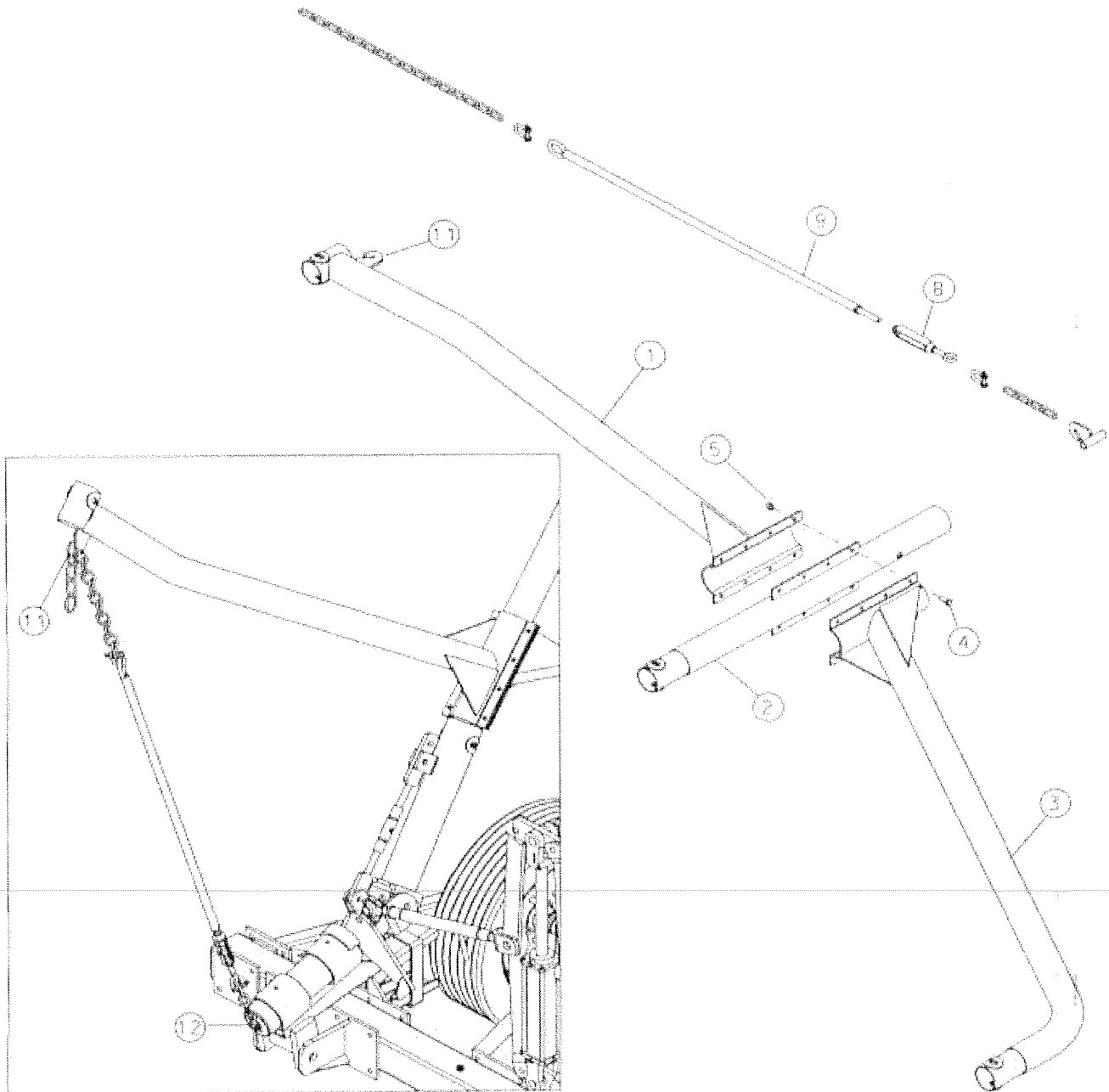

ASSEMBLE THE FRONT FRAME (1) AND THE REAR FRAME (3) TO THE CENTRAL ONE (2) USING 8 SCREWS TE M10x30 (4) AND LOCK NUTS (5). HOOK UP THE TRUSS LINK (9) TO THE HOOK ON THE PIVOTING HEAD (12) AND TO THE MAIN FRAME HOOK (11) (AS PER DRAWING). ADJUST TRUSS LINK TENSION USING THE TURNBUCKLE (8). THERE MUST BE A SLIGHT TENSION ON THE TRUSS LINK WHEN THE RAKE IS STATIONARY IN WORKING POSITION.

## INSTALL RAKE WHEEL FRAMES

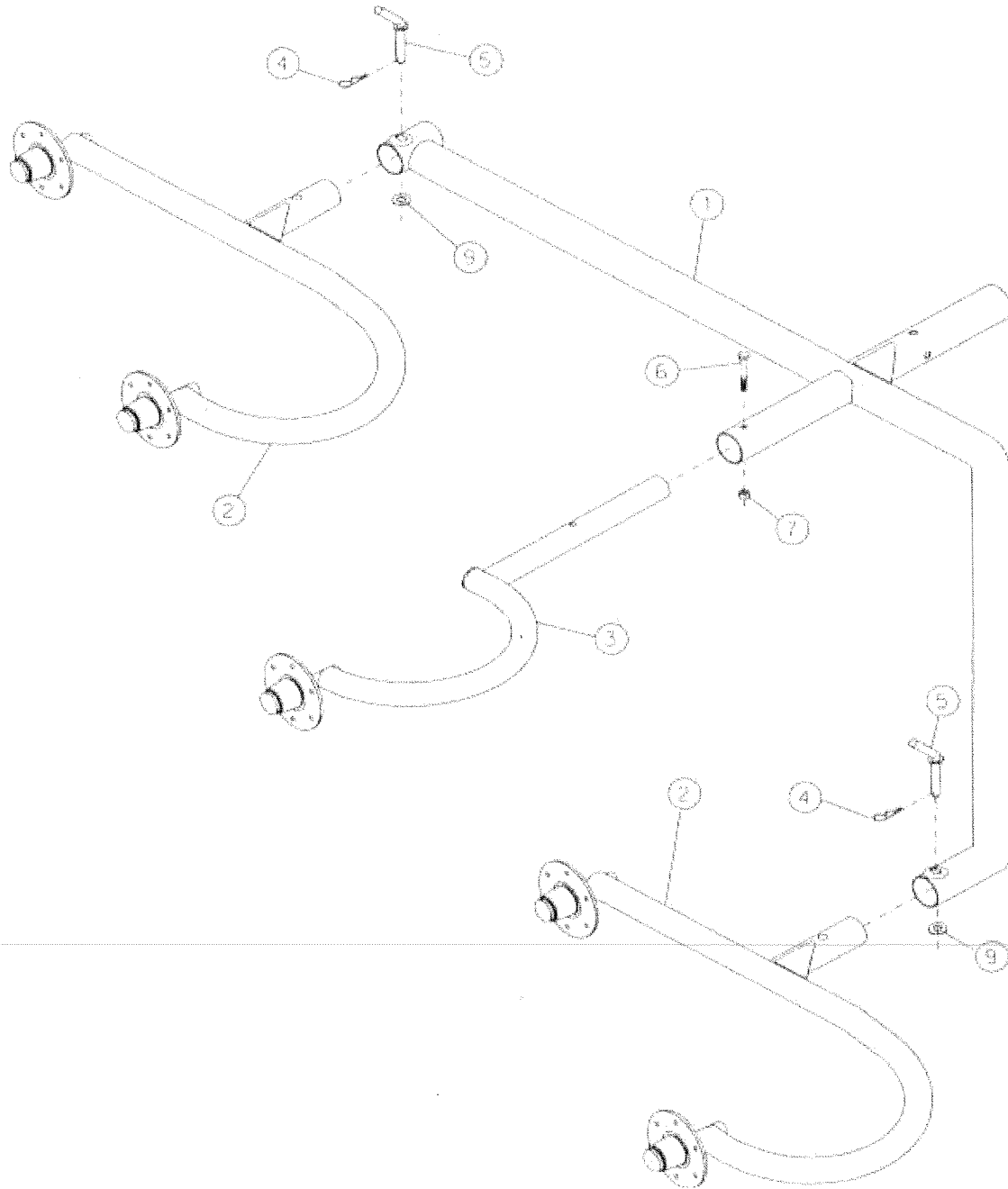

INSTALL RIGHT-HAND WHEEL FRAME (2) TO THE RIGHT-HAND MAIN FRAME (1).  
FASTEN WITH M16 PIN (5), WASHER (9) AND SPRING-LOCKING PIN (4).  
INSTALL RIGHT-HAND WHEEL FRAME (3) TO THE MIDDLE OF THE RIGHT-HAND MAIN FRAME (1).  
FASTEN WITH M12x80 CAP SCREW (6) AND LOCK NUT (7).  
REPEAT PROCEDURE ON LEFT-HAND SIDE.

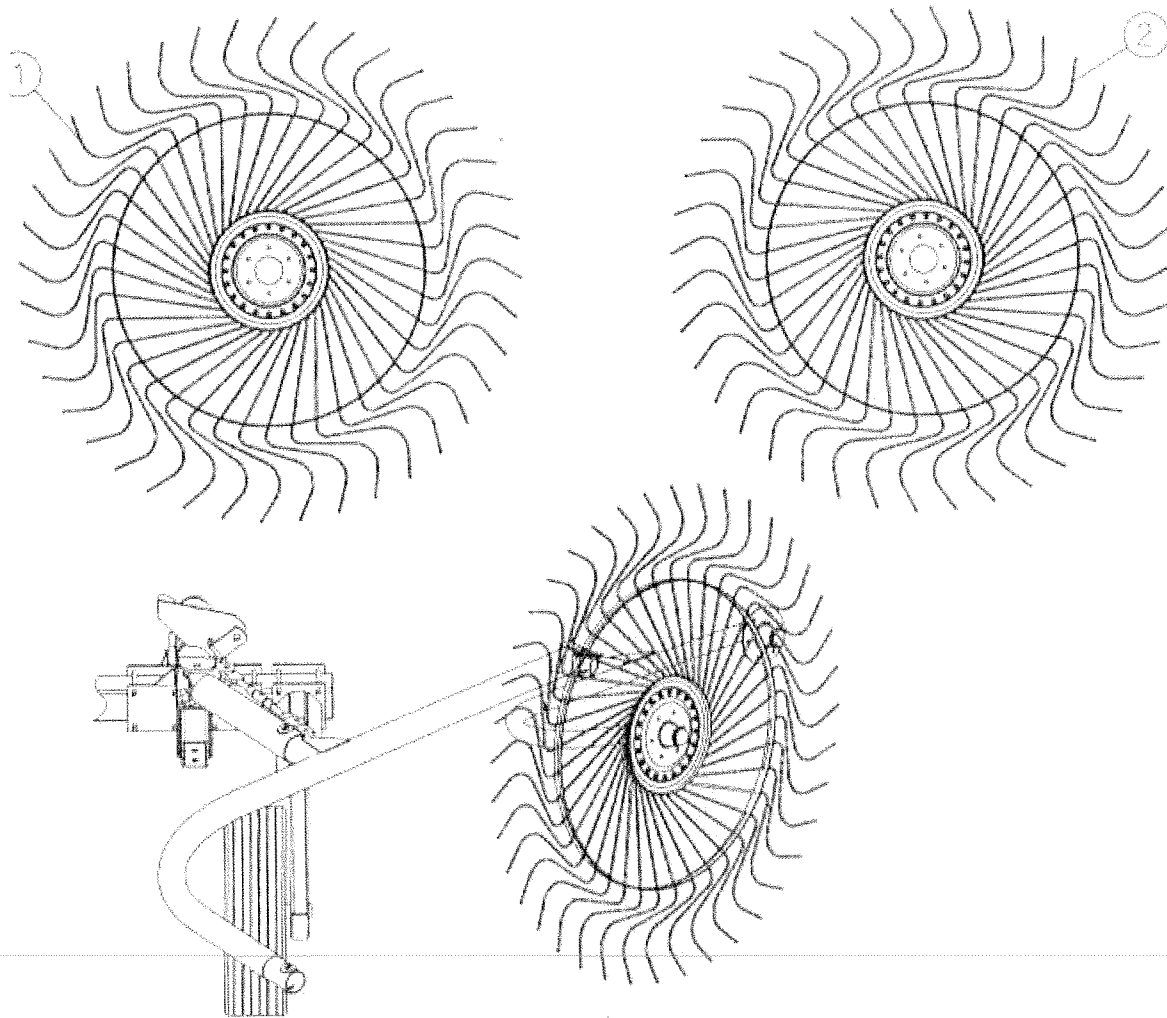
**INSTALL RAKE WHEELS**

IDENTIFY AND SEPARATE LEFT-HAND AND RIGHT-HAND RAKE WHEELS.

LEAN RAKE WHEELS AGAINST A WALL WITH TINE MOUNTING CLIP NUTS FACING OUTWARD. IF THE LAST BEND IN THE TINES CURVE TO A CLOCKWISE DIRECTION, IT IS A LEFT-HAND RAKE WHEEL (1)

IF THE TINES CURVE IN A COUNTERCLOCKWISE DIRECTION, IT IS A RIGHT-HAND RAKE WHEEL (2)

INSTALL RIGHT-HAND RAKE WHEEL WITH TINE CLIPS TO THE FRONT.

FASTEN WITH SIX M10x25 CAP SCREWS, FLAT WASHERS, AND NUT. INSTALL BOLT HEADS TO THE INSIDE WITH WASHERS AND NUTS TO THE OUTSIDE. REPEAT PROCEDURE FOR REMAINING RAKE WHEELS.

## INSTALL HYDRAULIC HOSE

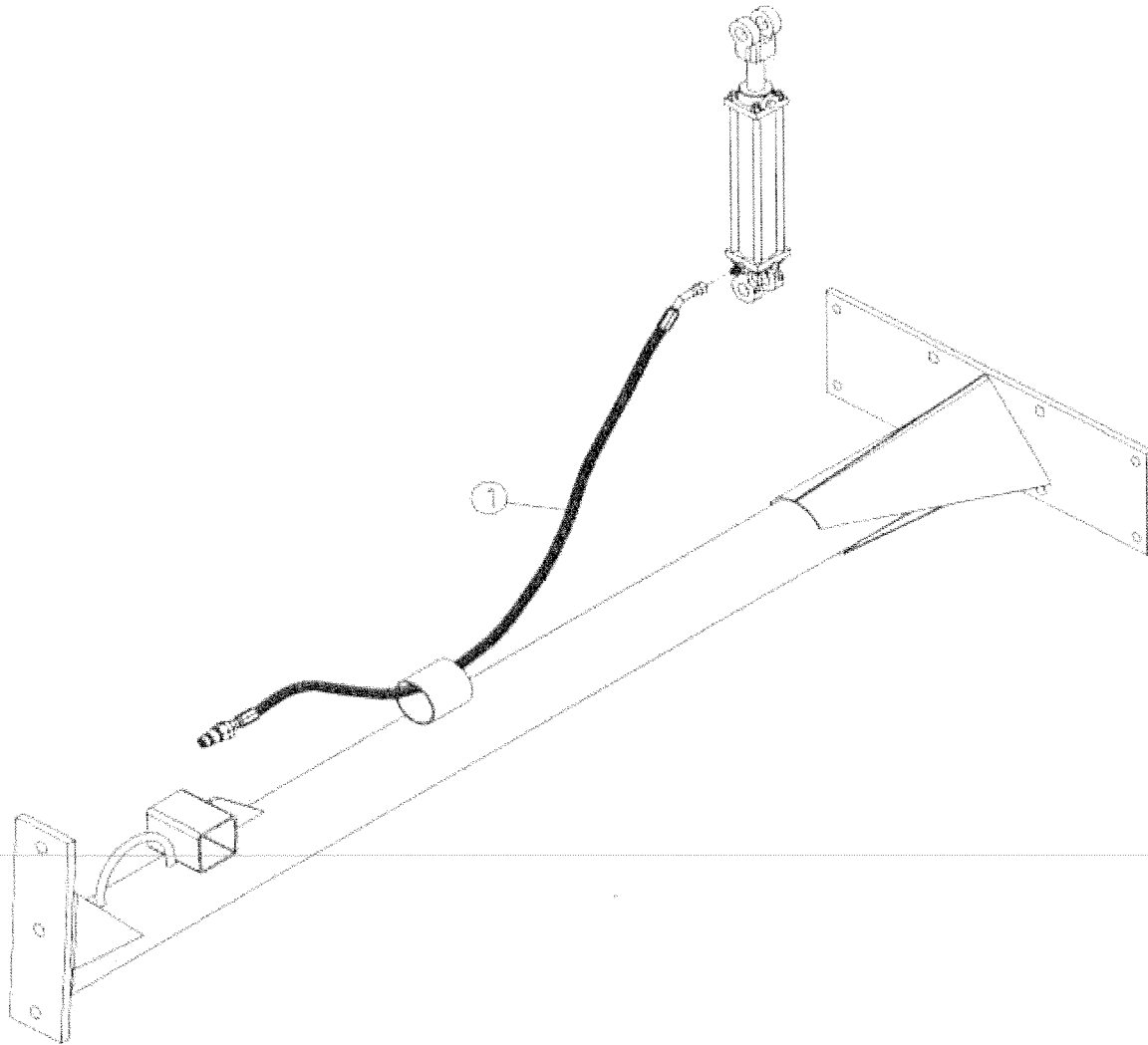

ATTACH HYDRAULIC HOSE (1) TO CYLINDER.

## HYDRAULIC CONNECTIONS

### Rake lifting system

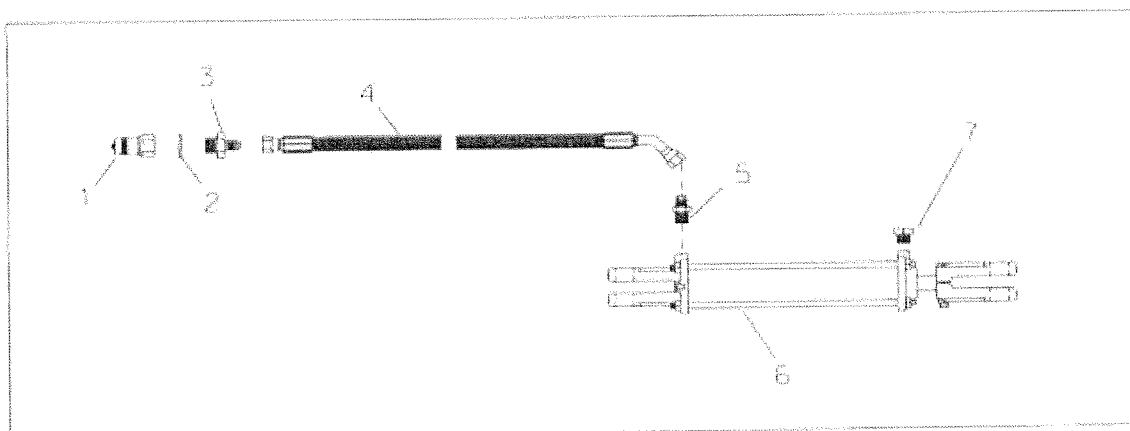

**WARNING :** Any different sized cylinders could cause serious damage to the lifting system of the rake.

N#	CODE#	DESCRIPTION	Q.TY
1	C25E0001	FAST FLUID CONNECTOR 1/2" PIONEER	01
2	C25F0010	WASHER+OR 1/2" GAS CYL.	01
3	C25A0010	FITTING 1/2"x9/16" - 18 JIC	01
4	C22A0007	WASHER+OR 1/2" GAS CYL.	01
5	C25A0005	ORIFICE F3 3/8 NPTF 9/16-18 JIC	01
6	C50BN007	HYD.CYLINDER	01
7	C25L0001	VALVE FOR CYLINDER 3/8"	01

## CENTER KICKER WHEEL

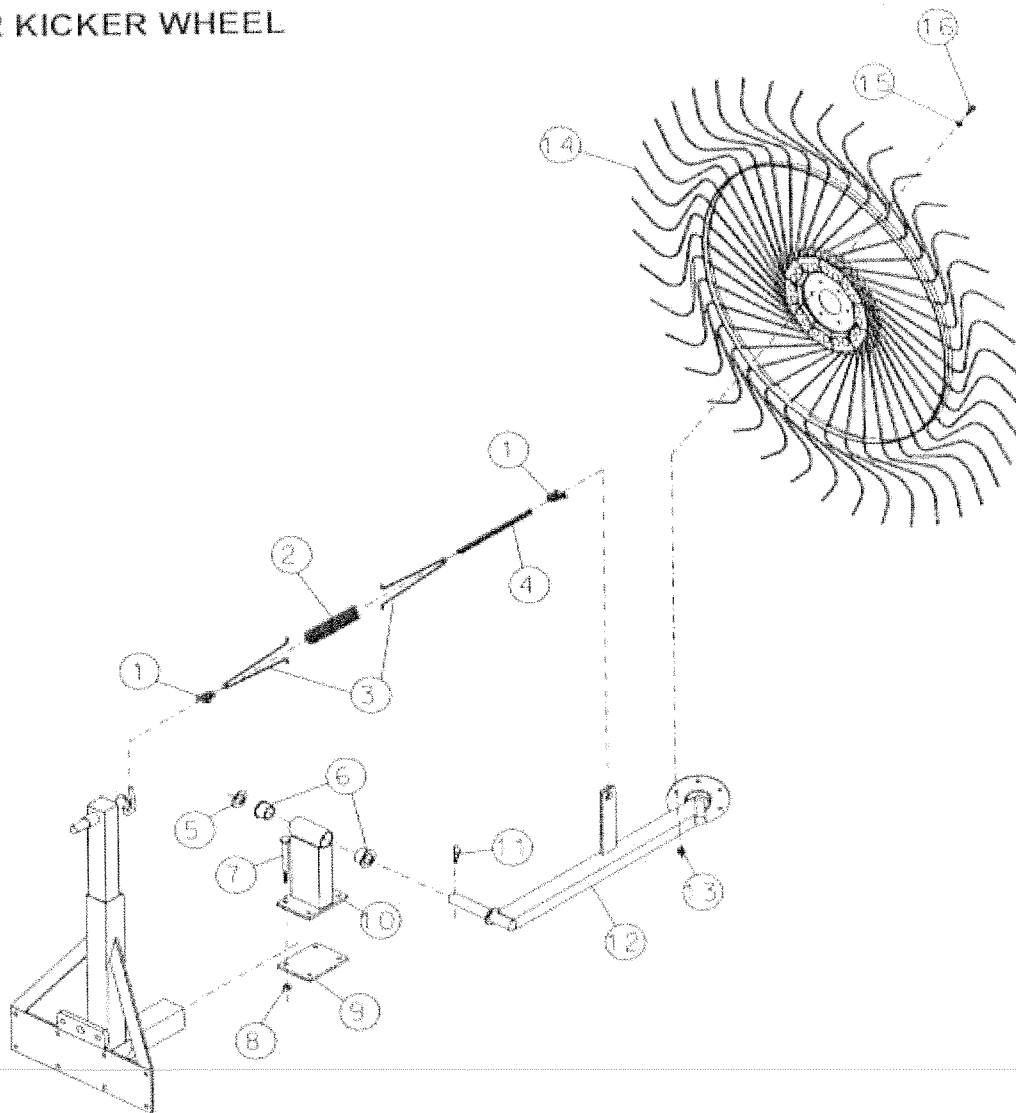

INSTALL WHEEL MOUNTING BRACKET (10) AND PLATE (9). FASTEN WITH FOUR M12x110 CAP SCREWS, LOCK WASHERS AND NUTS.

INSTALL NYLON BUSHING (6) IN MOUNTING BRACKET. SEAT BUSHINGS WITH RUBBER MALLET.

INSTALL RAKE WHEEL ARM (12) TO MOUNTING BRACKET. FASTEN WITH WASHER (5) AND SPRING LOCK PIN (11). ATTACH CHAIN (2) TO V-CLIP (3). PUSH V-CLIP (A) WITH CHAIN THROUGH SPRING.

INSTALL CLEVIS (1) ONTO V-CLIP (3).

INSTALL CLEVIS (1) ON THE NINTH CHAIN LINK FROM V-CLIP (3).

INSTALL CHAIN CLEVIS TO CYLINDER PIN. FASTEN WITH CLEVIS PIN. INSTALL CLEVIS (1) TO RAKE

WHEEL ARM BRACKET. FASTEN WITH CLEVIS PIN.

INSTALL WHEEL WITH TINE CLIPS TO THE FRONT OF MACHINE. FASTEN WITH SIX M10x25 CAP SCREWS

WITH HEADS TO FRONT OF MACHINE. INSTALL FLAT WASHERS AND NUTS TO THE REAR OF MACHINE.

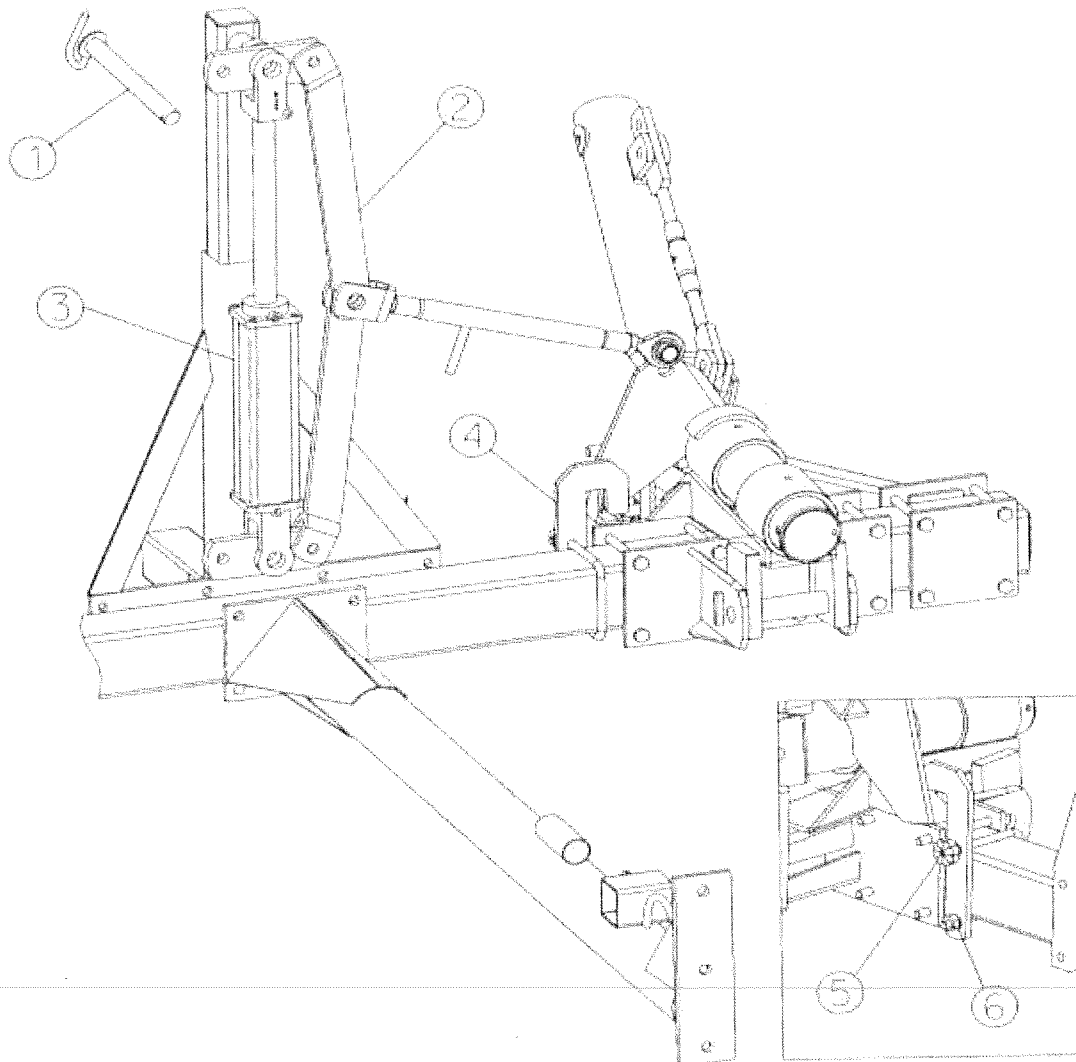
**KIT BLOCKING ONE RAKE**

DISCONNECT THE HYDRAULIC CYLINDER FROM THE CYLINDER GUIDE REMOVING THE PIN (1) AND THEN REPLACE THE SAME PIN (1) BACK INTO POSITION. THIS IS TO ALLOW THE PANTOGRAPH APPARATUS (2) TO MOVE FREELY, WITHOUT CAUSING ANY BENDING IN PARTS.

MAKE SURE THAT THE HYDRAULIC CYLINDER (3) IS NOT A DOUBLE ACTION CYLINDER BUT A SINGLE ACTION ONE.

ASSEMBLE THE RAKE BLOCKAGE PLATE (4) WITH THE U-BOLT ONTO THE SIDE OF THE TOOLBAR WITH WHICH YOU DO NOT WANT THE RAKE TO WORK AND BLOCK ONTO THE RAKE HEAD WITH RELATIVE KNOB (5) AND NUT WITH WASHER (6). N.B. PLEASE TAKE CARE NOT TO TIGHTEN WITH A TOOL THE NUT (6), BUT MAKE SURE IT IS THREADED TO TOUCH THE RAKE BLOCKING PLATE.

**SET WINDROW WIDTH**

Set windrow width to desired setting by sliding pivot frame and adjusting turnbuckle (1). Tighten bolts (2). Repeat on opposite side.

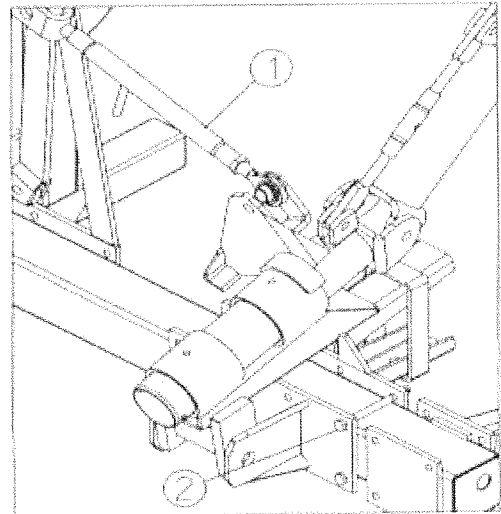
**RAKE WHEEL ANGLE SETTINGS**

Loosen lock nut (3) and rotate the turnbuckle (4) to move the pivot head assembly.

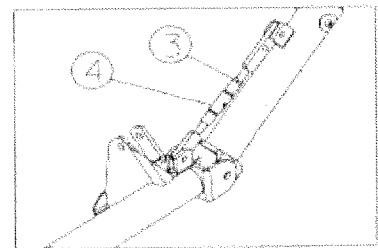
**COMPLETE AND CHECK ASSEMBLY**

- Tighten all nuts and check torque.
- Check operation of hydraulic cylinder.
- Install cylinder safety lock (5).

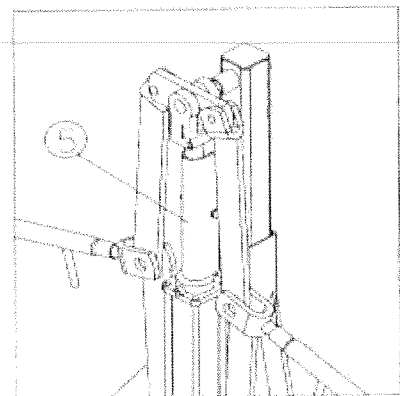



## TRACTOR REQUIREMENTS



**WARNING:** Do not operate or transport the rake with a tractor that does not meet the following requirements:

- Minimum Horsepower:
  - RCS 8 - HP 20 (15 kw)
  - RCS 10 - HP 20 (15 kw)
  - RCS 12 - HP 25 (19 kw)
- Upright exhaust.
- 1000 psi minimum hydraulic pressure, suggested 6 gpm flow rate.
- Adequate brakes, tires weighting, and steering control.

## HITCH IMPLEMENT TO TRACTOR

1. When hitched implement to tractor.  
Secure jack/stand (1) in transport position.
2. Connect hydraulic hose to tractor.
3. Remove any storage grease from cylinders.

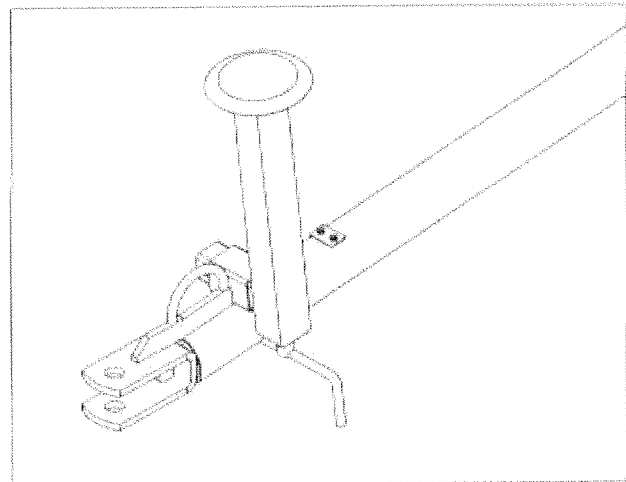

**WARNING:** Obey all applicable laws vehicle sign, safety chain and other possible requirements concerning road use. Use good judgement and drive carefully.

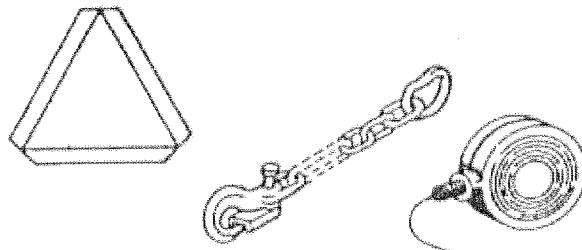

### TRANSPORTING

- Before transporting the rake, clean out any crop and chaff that has become trapped between the rake lines and the frame. Then raise into the transport position.



**WARNING:** Serious injury or death could occur if rake arms collide with vehicles or fixed objects during transport.

- Install cylinder stop (1) to prevent rake arms from dropping during transport.

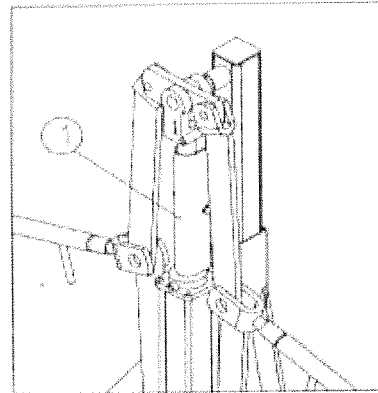

### STORE CYLINDER STOP

Install cylinder stop (2) in storage position. Fasten with spring-clip pin.

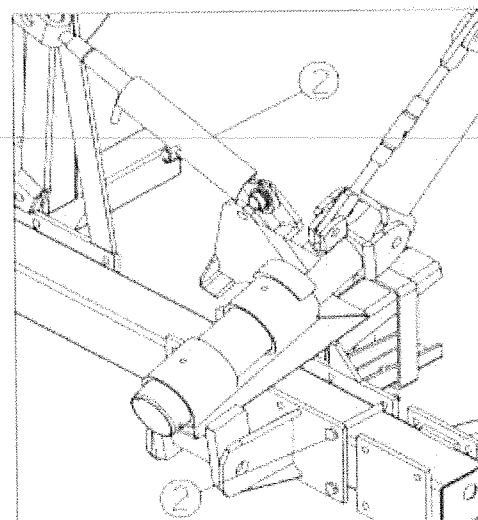

---

**UNHOOKING**

**WARNING:** Use the Normal Shutdown Procedure section when unhooking Implement.

Park the implement on level ground.

Lower implement or install cylinder stop.

Set jack/stand .

Unhook cylinder hose , safety chain and hitch pin.

---

**Prepare implement for season storage :**

- Remove dirt and crop from implement. Paint exposed metal to inhibit rusting.
- Lubricate grease points on the machine.
- Coat exposed hydraulic cylinder rod(s) with grease to prevent rusting.
- Check hydraulic hoses for deterioration and replace if necessary.
- Tighten any loose bolts, nuts and hydraulic fittings.
- Repair or replace worn or broken parts.
- Replace damaged or missing decals.

### NORMAL SHUTDOWN PROCEDURE



**WARNING:** before making adjustments to rake, follow normal shutdown procedure.

1. Follow normal shutdown procedure for the tractor (refer to the tractor operators manual). Shut off tractor, set brake or park lock and lower attachments to ground.

2. Lower rake to ground or install lock (1) whenever leaving tractor. Do not work on rake unless rake is lowered or cylinder is locked.

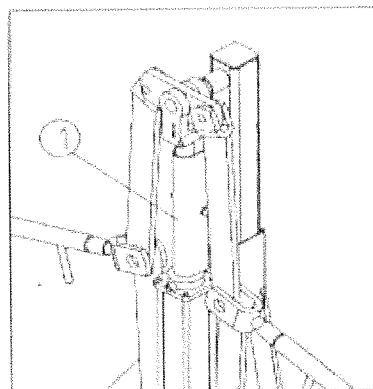

### RAKE ADJUSTMENT

#### WHEEL HEIGHT

Adjust tire wheels for correct field and transport position. Refer to Adjust Main Frame, Assembly Section.

If minor adjustment to correct wheel downpressure is needed, loosen locknut (3) and rotate turnbuckle (4) to adjust. Tighten locknut.

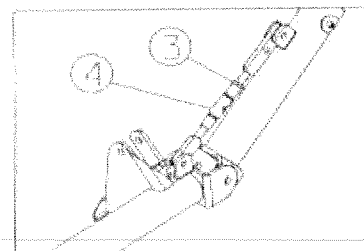

#### WINDROW WIDTH ADJUSTMENT

Adjust windrow width to match baler pickup width. Refer to Rake Adjustment, Assembly Section.

### DIRECTION OF TRAVEL

Raking direction will effect leaf loss and bale formation.

For sickle mowed crop, rake in the same direction as mower travel.

For rotary mowed crop, rake in opposite direction as mower travel

Experimentation may be necessary for best bale formation

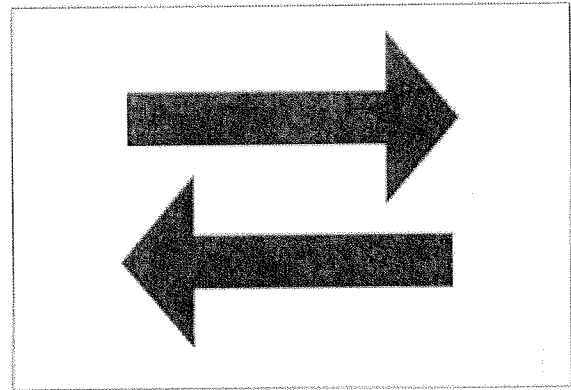

### RAKING SPEED

Optimum ground speed will depend on crop being raked, terrain, and tractor horsepower. Reduced ground speed may be necessary for hills or rough terrain. Inexperienced operators should use slower ground speeds and avoid rough or uneven terrain which could lead to tractor tipping or rollover.

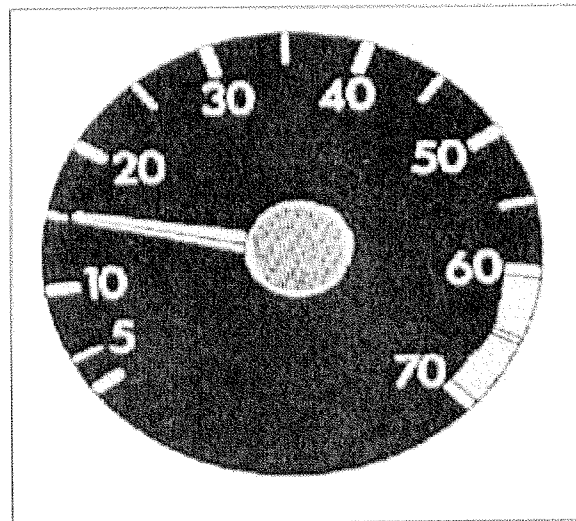

### TROUBLESHOOTING

Most raking problems can be traced to travelling too slow or too fast, incorrect ground pressure, or broken or missing tines.

Increase ground pressure only enough to pick up crop.

## WORKING WIDTH

*NOTE: Windrow widths (A) and (B) are approximate.*

The working width and windrow width will vary according to the type and quantity of crop being raked.

The distance between hoops on rear raking wheels can be used to determine basic windrow width. Actual width depend on crop type, volume, and raking speed.

When adjusting with turnbuckle, working width will change.

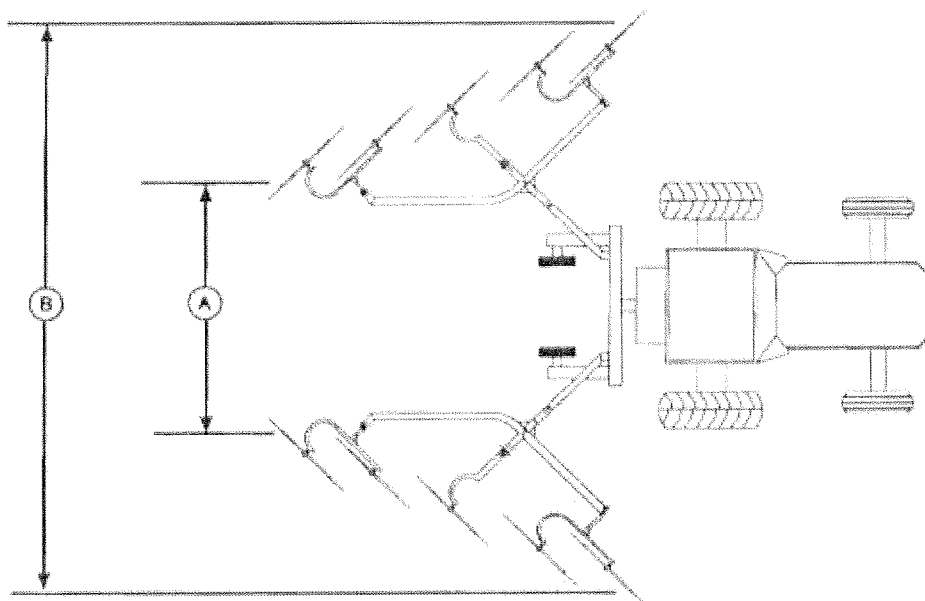

WINDROW WIDTH (A)	WORKING WIDTH 8 WHEEL RAKE (B)	WORKING WIDTH 10 WHEEL RAKE (B)	WORKING WIDTH 12 WHEEL RAKE (B)
1,22 TO 1,83 m (4' TO 6')	5,38 TO 5,99 m (17' 8" TO 19'8")	6,10 TO 6,71 m (20' TO 22')	6,71 TO 7,30 m (22' TO 24'4")

## HYDRAULIC PROBLEMS

Problem	Probable Cause	Possible Solution
Hydraulic System Inoperative	Auxiliary outlet not activated	Activate auxiliary hydraulic outlet
	Hose from implement not properly connected to tractor	Connect hose
	Hydraulic oil level too low in tractor	Check tractor operator's manual for proper oil level

*NOTE: "Oil leaks may be experienced with new cylinders when used in single action mode. Please note that this is not a fault in the cylinder, but just the extra oil remaining inside the cylinders body after the cylinders have gone through the Quality Control Audits in the Walton factory being pushed out in double action mode."*

## RAKING PROBLEMS

Problem	Cause	Solution
Field not cleaned well	Rake wheel assemblies too high	Adjust assemblies lower to ground
Hay is bunching	Tips of teeth collecting dirt	Remove paint and dirt from tips of teeth
	Incorrect ground speed	Adjust ground speed
Rake wheel hoops breaking	Excessive ground speed	Reduce ground speed
	Excessive ground pressure	Reduce ground pressure
Tines breaking	Excessive ground speed	Reduce ground speed
	Excessive ground pressure	Reduce ground pressure
One rake wheel does not turn	Inadequate lubrication	Lubricate adequately
	Worn or damaged bearing	Replace bearing
Poor windrow preparation	Rake wheel assemblies too high	Adjust assemblies lower to ground
	Broken or missing tines	Replace tines
	Excessive ground speed	Reduce ground speed
	Excessive ground pressure	Reduce ground pressure
Rake wheel assembly on one side does not turn	Rake wheel assembly too high	Adjust assembly lower to ground
	Broken or missing tines	Replace tines

**LUBRICATION AND MAINTENANCE****MAINTENANCE - 10 SERVICE HOURS**

After the first hours of operation, check all attaching hardware. All hardware torques should be checked on a routine basis after every 10 hours of operation.

**MAINTENANCE - 50 SERVICE HOURS**

- 1 -One shot of grease. Two grease zerks each pivot tube.
- 2 -Coat cylinder guide with grease.

**MAINTENANCE - 250 SERVICE HOURS**

- 3 - Oil the jack lightly.
- 4 - Oil turnbuckle threads as needed

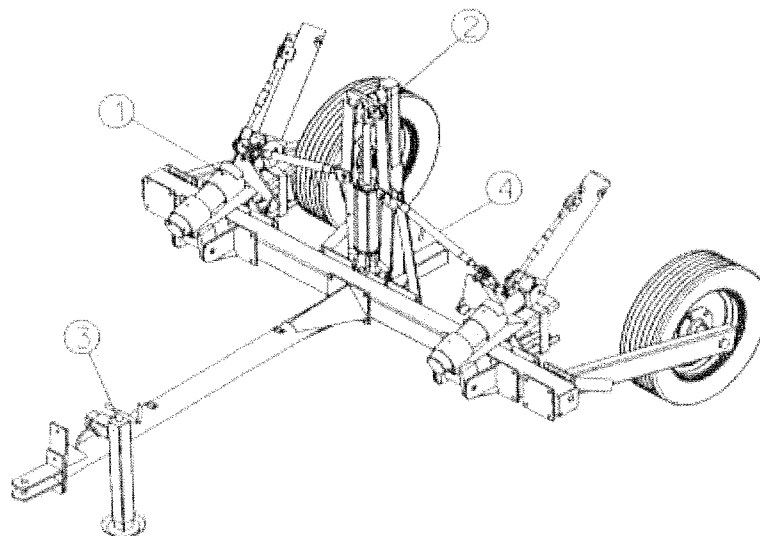
**MAINTENANCE - AS REQUIRED**

Periodically inspect rake and make necessary repairs.

- Check frame for fatigue or cracking. Replace or repair worn or damaged parts.
- Check decals. replace if missing or damaged.
- Check bolts and fasteners. Tighten or replace as necessary.
- Check tire pressure. Inflate to 40 psi (2.7bar)
- Check tires and rims for damage.
- Check lug nut torque. torque to 85 ft lb (115 nm).
- Check condition of rake wheels.
- Check hydraulic cylinders and hoses for leaks or damage.



**CHECK WHEEL BEARINGS**

Yearly, or if ground wheel or tine wheel bearings do not turn freely, check bearing grease.

*NOTE: Support implement on blocks if checking ground wheel bearing.*

**INSPECT BEARING**

1- Remove dust cap (1), cotter pin and castle nut or locking nut (2), and washer and outer bearing (3).

2 - Inspect bearing: if it is dry, or if grease is caked or contaminated, repack bearings; otherwise go to step 8.

**REPACK BEARING**

3- Remove wheel and hub. Remove and inspect seal (5). Replace if damaged.

4- Remove the inner bearing (4).

5- Wash bearings and inside of hub with solvent. Wipe clean and air dry. Replace damaged bearings or races.

6- Work grease into roller retainers from edge to fill the entire bearing with grease.

7- Install inner bearing (4), seal (5), into hub and mount on spindle.

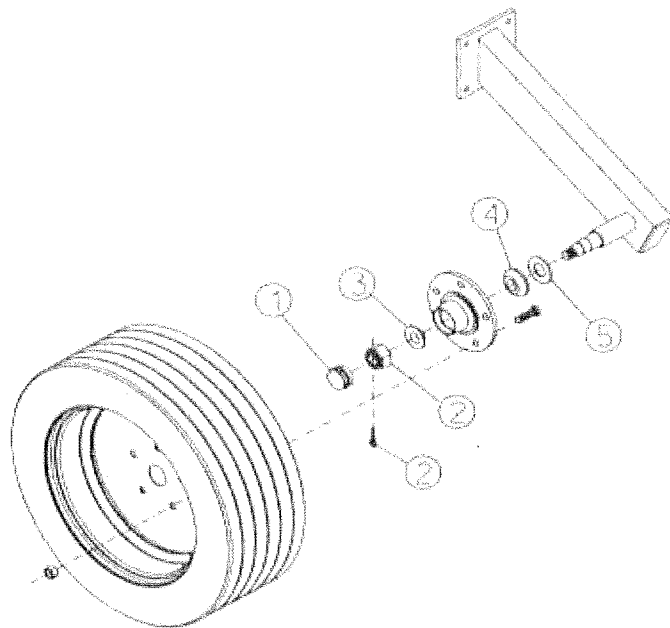
**PRELOAD BEARING**



8- Install outside bearing and washer (3) install nut (2).

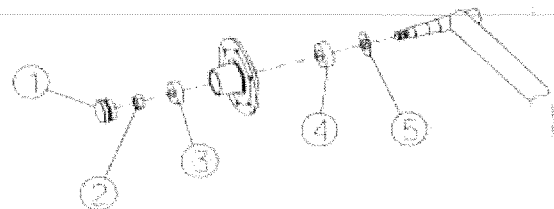

9- Tighten nut until slight drag is felt when turning wheel. Back off nut 1/8-1/4 turn (locknut type) or until first slot lines up with hole in spindle and install cotter pin (castle nut type). Install dust cap (1).

10- Install wheel and torque nuts or bolts.

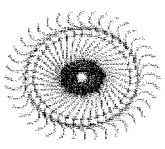
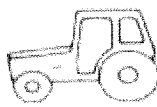
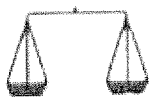

## SPECIFICATIONS

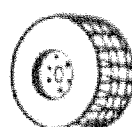
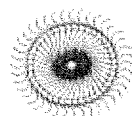
MODEL						 TRANSPORT	
	NUMBER	KW	HP	LBS	KG	FEET	CM
RCS 8	8	15	20	1038	472	10'	300
RCS 10	10	15	20	1174	534	10'4"	320
RCS 12	12	19	25	1386	630	11'4"	340

MODEL	 SPEED			 WHEELS DIAM.		 WORKING W.	
	MPH	KMH	TIRES	INCH	CM	FEET	CM
RCS 8	14	22	175/70-14	55"	140	19'8"	590
RCS 10	14	22	175/70-14	55"	140	22'	660
RCS 12	14	22	175/70-14	55"	140	24'4"	730

## HYDRAULIC FITTINGS

### Pipe Thread fittings



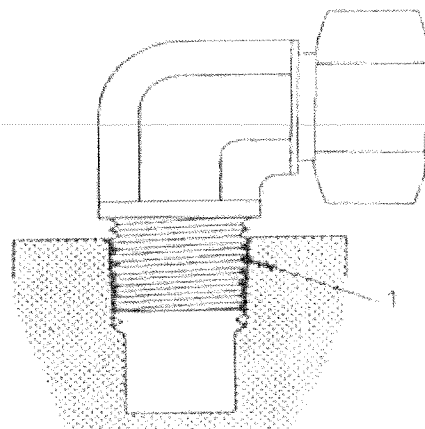

Make sure the threads (1) are free from nicks, burrs, dirt, etc.

Tighten the fitting approximately 3 turns past finger tight.



## RECOMMENDED TORQUE VALUES

For Metric Grade 5.8, 6.9, 10.9, & 12.9 Cap Screws and Bolts  
 All values are ft. lbs.

BOLT SIZE	 GRADE 5.8		 GRADE 6.9		 GRADE 8.8		 GRADE 10.9		 GRADE 12.9	
	FT. LBS.	Newton Meters	FT. LBS.	Newton Meters	FT. LBS.	Newton Meters	FT. LBS.	Newton Meters	FT. LBS.	Newton Meters
M4	1.1	1.5	1.7	2.3	2	2.7	2.9	4	3.6	5
M5	2.3	3.1	3.5	4.7	4	5.4	6	8	7	9.5
M6	3.9	5.3	5.8	7.8	7	9.5	10	13.5	11	15
M7	6.5	8.8	9.4	12.7	11	15	16	22	20	27
M8	10	13.5	14	19	18	24	25	34	29	39
M10	20	27	29	39	32	43	47	64	58	79
M12	34	46	50	68	58	79	83	112.5	100	136
M14	54	73	79	107	94	127	133	180	159	216
M16	80	108.5	122	165	144	195	196	266	235	319
M18	114	155	170	230.5	190	258	269	365	323	438
M20	162	220	220	298	260	353	366	496	440	597
M22	202	274	318	431	368	499	520	705	628	852
M24	245	332	410	556	470	637	664	900	794	1077
M27	360	488	606	822	707	959	996	1351	1205	1634
M30	500	678	815	1105	967	1311	1357	1840	1630	2210

**WALTON<sup>®</sup>**

PMUS03RCS-0305W

---

## CARTED HAY RAKES RCS 8-10-12

### PARTS LIST

When ordering spare parts or asking for technical information on your rake,  
please be sure to always mention the implement's serial numbers.

This is very important when ordering spare parts.

Always use only original Walton spare parts so as not to incur in any problems  
regarding the warranty policy for this implement.

## PIVOT HEAD ASSEMBLY RCS 8-10-12

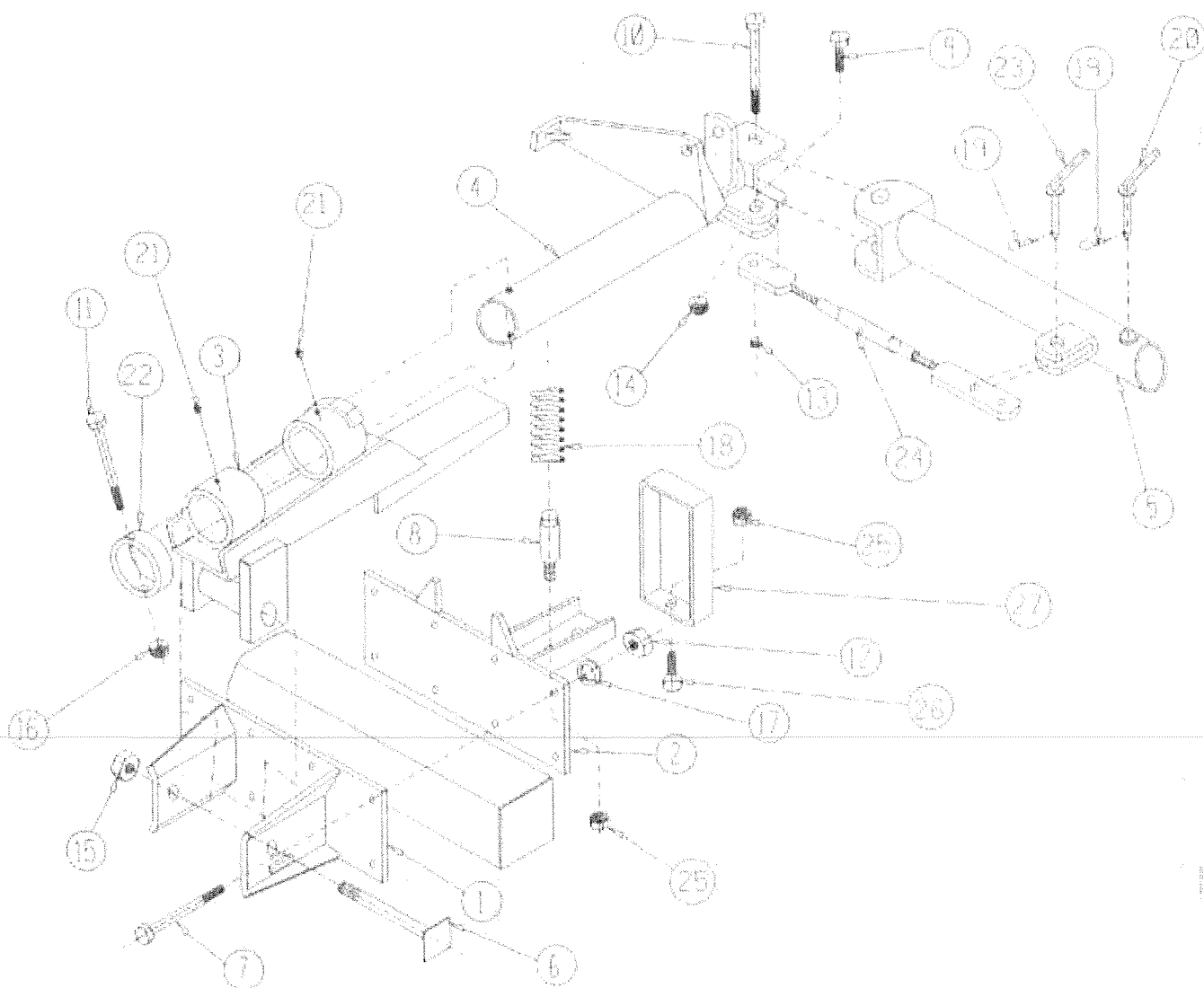

**PIVOT HEAD ASSEMBLY RCS 8-10-12**

N#	CODE#	DESCRIPTION	Q.TY
1	P50DR011	SUPPORT FOR HEAD RCS	02
2	P50DR012	SUPPORT FOR SPRING FLOATATION RCS	02
3	P50NR019	SUPPORT FOR RAKE FRAMES	02
4	P50ZR003	PIVOT FOR FRAME L.H. RCS	01
	P50ZR002	PIVOT FOR FRAME R.H. RCS	01
5	P50ZR005	PIVOT MOVEABLE L.H. RCS	01
	P50ZR004	PIVOT MOVEABLE R.H. RCS	01
6	C70BZ006	PIVOT FOR HEAD CARRYING FRAME ZN.RC	02
7	V10AZ046	HEX.CAP SCREW TE M12x140 UNI 5737 Z	16
8	C70BZ003	PIVOT FOR SPRING ZINCED RCS	02
9	V10AZ057	SCREW TE M 16x55 UNI 5739 ZINCED	02
10	V10AZ129	SCREW TE M20x150 UNI 5737 ZINCED	02
11	V10AZ099	SCREW TE M10x120 UNI 5737 ZINCED	02
12	V20AZ004	HEXAGONAL NUT 6S M12 UNI 5588 ZN	16
13	V20CZ005	NUT METABLOCK M16 DIN 980 ZINCED	02
14	V20BZ019	SELF LOCKING NUT M20 UNI7474 ZN	02
15	V20BZ021	SELF LOCKING NUT NY M24x2 UNI7474 Z	02
16	V20CZ002	NUT METABLOCK M10 DIN 980 ZINCED	02
17	V30CZ004	SPRING LOCKWASHER M12 UNI1751 Z	16
18	C40AZ024	SPRING FOR FLOATATION GROUP ZINCED	02
19	V40CZ008	SPLIT PIN R d=4 ZINCED	04
20	C70AZ003	PIN FOR FRAME D=16 l=105 ZN	02
21	V99AZ001	GREASER 10 M5 UNI 7663-A	04
22	C40AZ030	RING ZINCED RCS	02
23	C70AZ001	LOCK PIN D=16 l=68 ZINCED	02
24	C30BZ001	TURNBUCKLE OPENING ZN. RCS	02
25	V20BZ007	SELF LOCKING NUT M18 UNI 7474 ZINC	02
26	V10AZ066	SCREW TE M18x50 UNI 5739 ZINCED	02
27	P50ZZ040	SAFETY BRACKET FOR SPRING ZINC RCS	02

MAIN FRAME ASSEMBLY - 4 WHEEL RCS 8

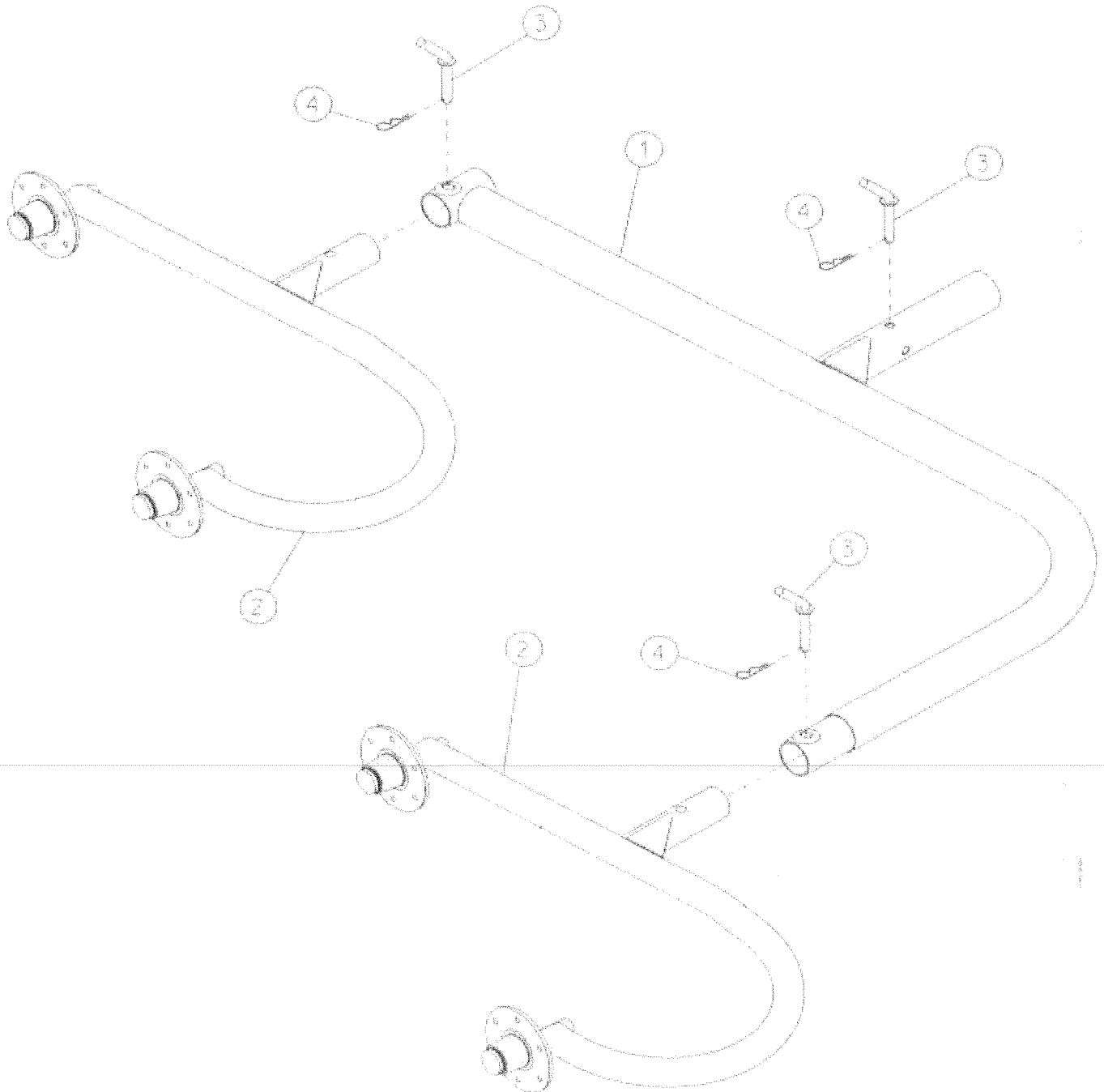



---

MAIN FRAME ASSEMBLY - 4 WHEEL RCS 8

N#	CODE#	DESCRIPTION	Q.TY
1	P50AR009	FRAME PINNED P4/90	01
2	P50BR015	ARM CARRYING RAKE WHEEL PINNED R.H.	02
	P50BR014	ARM CARRYING RAKE WHEEL PINNED L.H.	02
3	C70AZ002	LOCK PIN D=16 L=85 ZN	03
4	V40CZ008	SPLIT PIN R d=4 ZINCED	03



MAIN FRAME ASSEMBLY - 5 WHEEL RCS 10

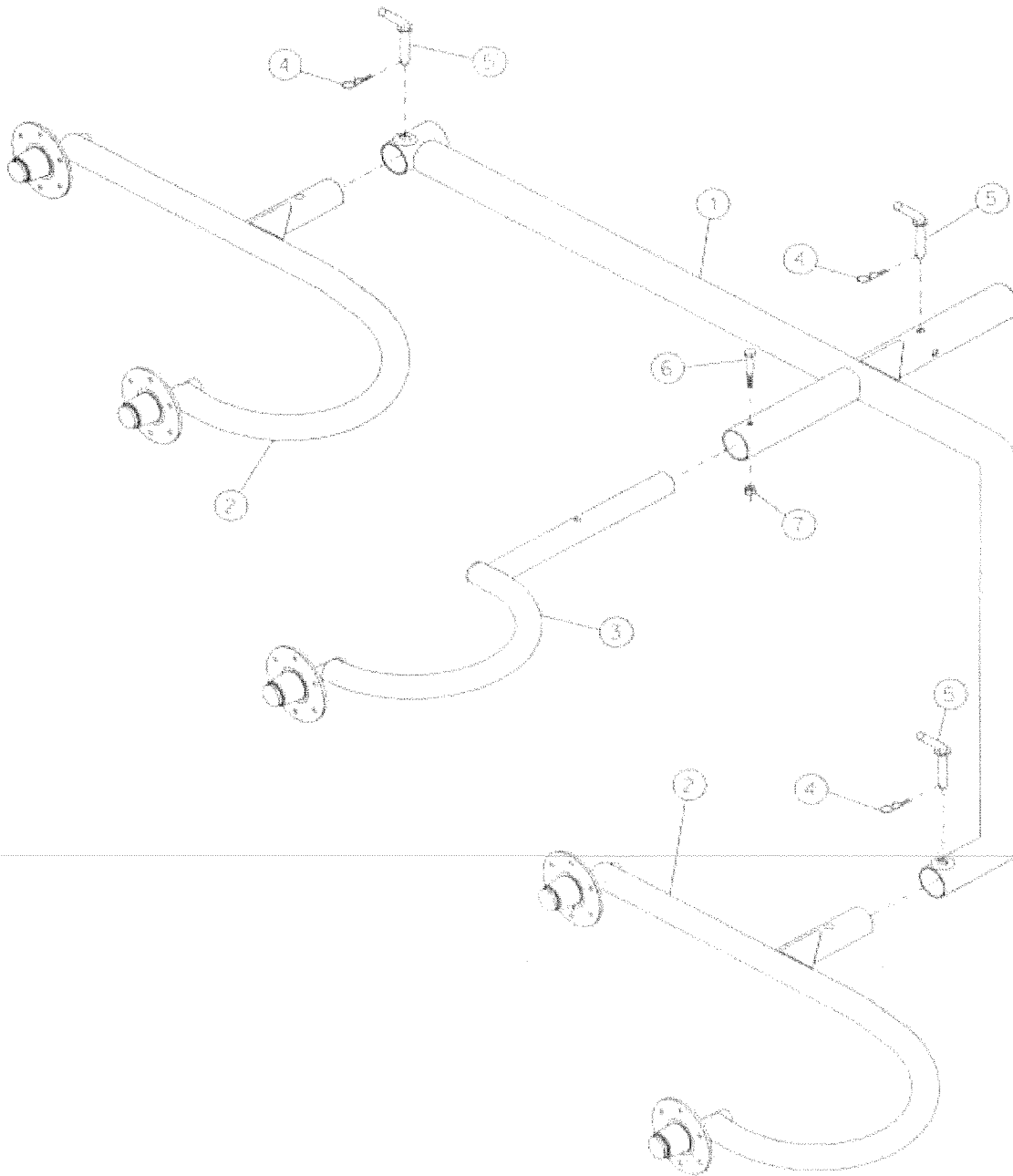

---

**MAIN FRAME ASSEMBLY - 5 WHEEL RCS 10**

N#	CODE#	DESCRIPTION	Q.TY
1	P50AR010	FRAME PINNED P5/90	01
2	P50BR015	ARM CARRYING RAKE WHEEL PINNED R.H.	02
	P50BR014	ARM CARRYING RAKE WHEEL PINNED L.H.	02
3	P50BR006	ARM CARRYING 5TH RAKE WHEEL R.H. P5	01
	P50BR007	ARM CARRYING 5TH RAKE WHEEL L.H. P5	01
4	V40CZ008	SPLIT PIN R d=4 ZINCED	03
5	C70AZ002	LOCK PIN D=16 L=85 ZN	03
6	V10AZ039	SCREW TE M12x80 UNI 5737 ZINCED	01
7	V20CZ003	NUT METABLOCK M12 DIN 980 ZINCED	01

## MAIN FRAME ASSEMBLY - 6 WHEEL RCS 12

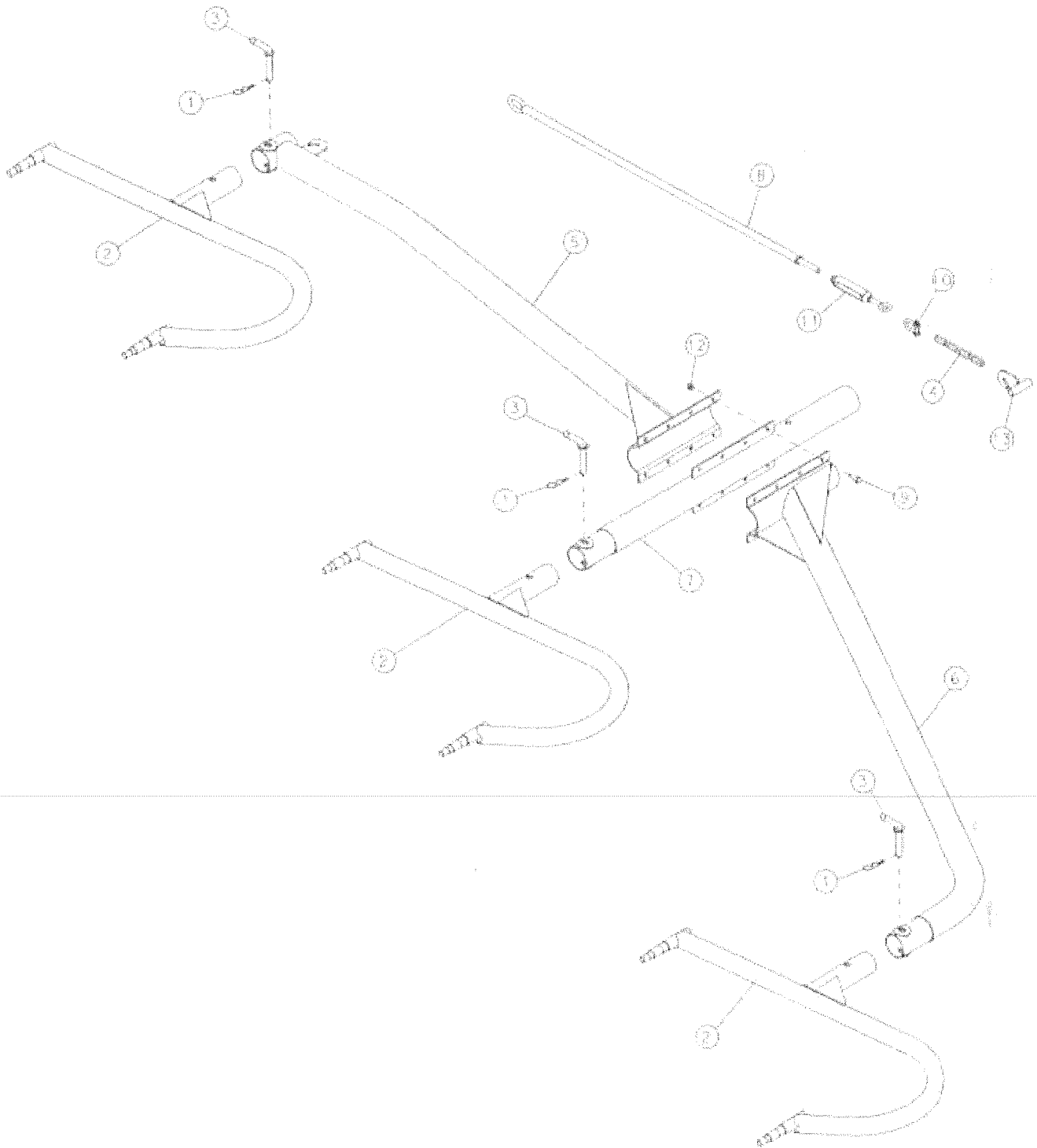

**MAIN FRAME ASSEMBLY - 6 WHEEL RCS 12**

N#	CODE#	DESCRIPTION	Q.TY
1	V40CZ008	SPLIT PIN R d=4 ZINCED	03
2	P50BR015	ARM CARRYING RAKE WHEEL PINNED R.H.	03
	P50BR014	ARM CARRYING RAKE WHEEL PINNED L.H.	03
3	C70AZ002	LOCK PIN D=16 L=85 ZN	03
4	C45AZ003	CHAIN 54x25x6 L=180 ZINCED	01
5	P50AR006	FRAME FRONT PINNED WITH HOOK RCS	01
6	P50AR157	FRAME REAR PINNED RCS	01
7	P50AR156	FRAME CENTRAL PINNED RCS	01
8	P50UR006	ROD FRAME RCS12	01
9	V10AZ016	SCREW TE M10x30 UNI 5739 ZINCED	08
10	V50AZ002	U SHACKLE D=8 ROBUR ZINCED	01
11	C30AZ008	TURNBUCKLE M14 ZINCED	01
12	V20CZ002	NUT METABLOCK M10 DIN 980 ZINCED	08
13	P50ZZ070	CHAIN ANCHOR ZINCED RCS 12/P6	01

## HYDRAULIC LIFT LINKAGE ASSEMBLY RCS 8-10-12

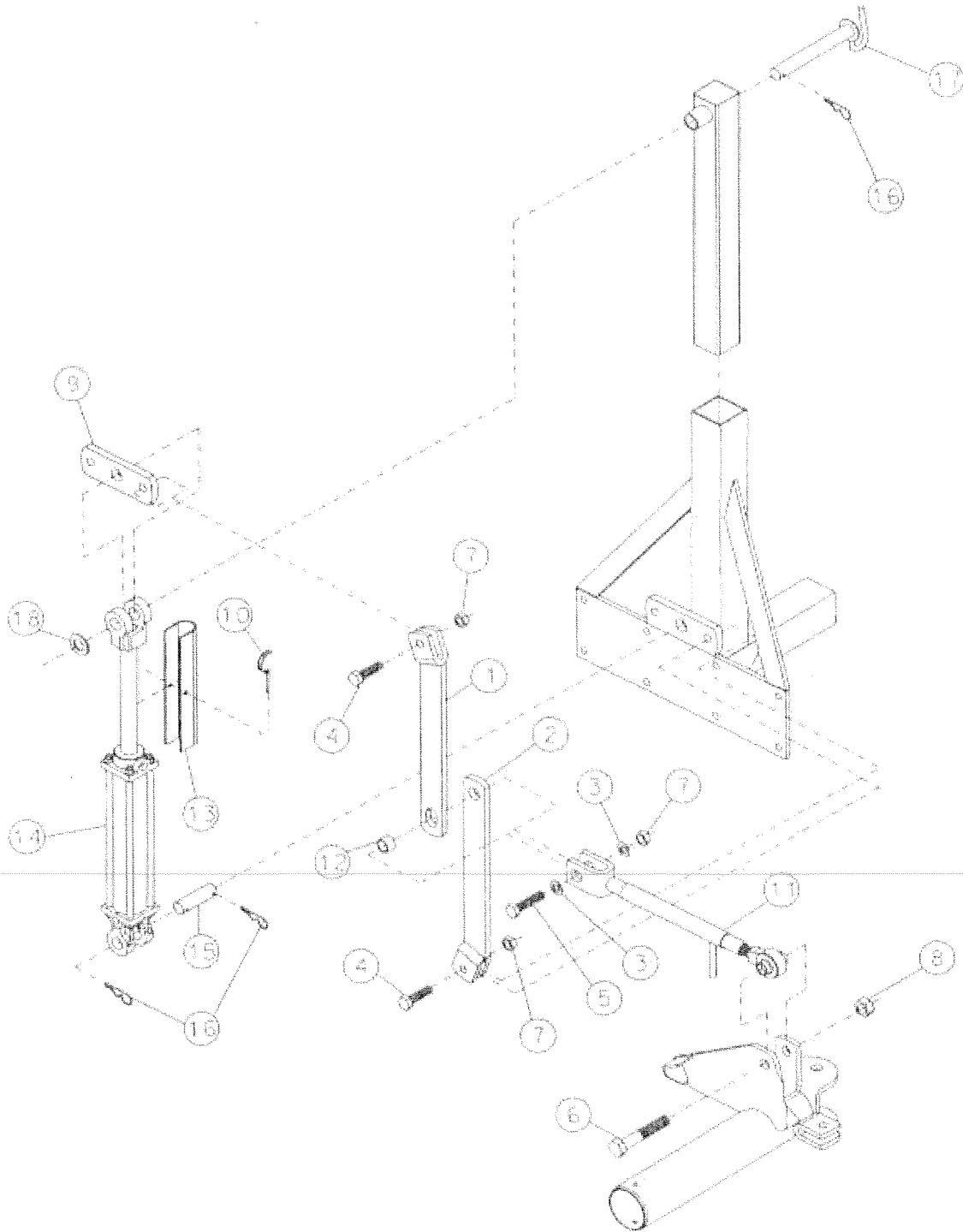

**HYDRAULIC LIFT LINKAGE ASSEMBLY RCS 8-10-12**

N#	CODE#	DESCRIPTION	Q.TY
1	P50BZ058	ARM PANTOGRAPH UPPER ZINCED RCS	02
2	P50BZ059	ARM PANTOGRAPH LOWER ZINCED	02
3	V30AZ008	WASHER M16 UNI 6592 ZINCED	04
4	V10AZ057	SCREW TE M 16x55 UNI 5739 ZINCED	04
5	V10AZ059	SCREW TE M16x70 UNI 5737 ZINCED	02
6	V10AZ075	SCREW TE M20x90 UNI 5737 ZINCED	02
7	V20CZ005	NUT METABLOCK M16 DIN 980 ZINCED	04
8	V20BZ019	SELF LOCKING NUT M20 UNI7474 ZN	02
9	P70AZ036	PLATE ATTACHMENT CYLINDER ZN RCS	01
10	V45BZ001	PIN/LOCK d=8 l=60	01
11	C30AZ005	TURNBUCKLE ZINCED l=620	02
11	C30AZ006	TURNBUCKLE L=445	02
12	C70CZ001	BUSHING FOR PANTOG.BLADE ZINCED RCS	02
13	P50HZ032	SAFETY LOCK FOR TRANSPORT RED RCS	01
14	C50BN003	HYD. CYLINDER	01
15	C70BZ012	PIN (CYLINDER)	01
16	V40CZ008	SPLIT PIN R d=4 ZINCED	03
17	C70BZ002	TOP CLYINDER PIN ZN RCS	01
18	V30AZ014	WASHER 25x50x2.5 ZINCED	01

WHEEL & HUB ASSEMBLY RCS 8-10-12

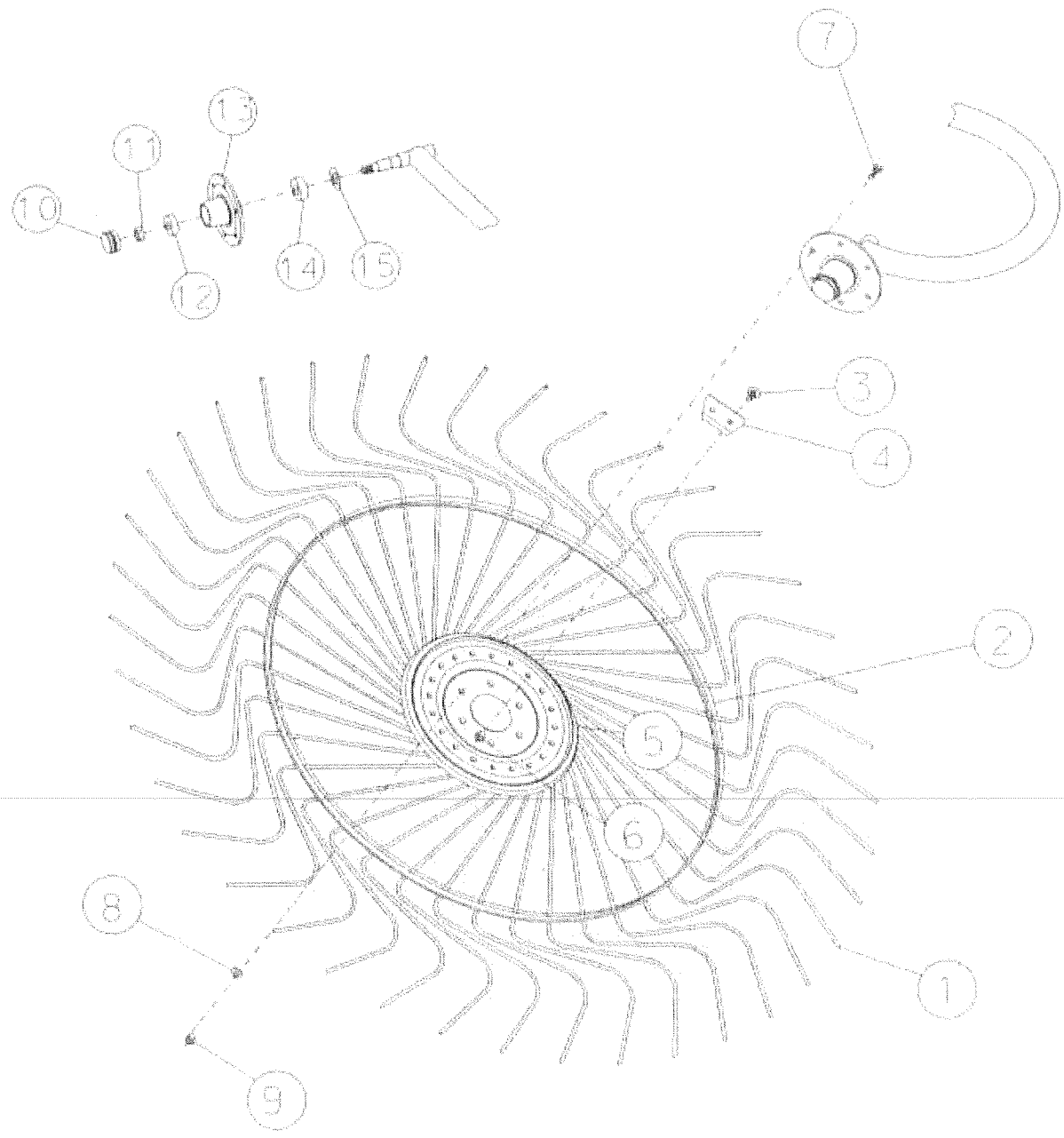

**WHEEL & HUB ASSEMBLY RCS 8-10-12**

N#	CODE#	DESCRIPTION	Q.TY
1	P25AG003	TINES STRAIGHT V BUNDLE OF 40 TINES	01
	P25AG001	TINES R.H.T.BUNDLE OF 40 TINES YELL	01
	P25AG002	TINES L.H.T BUNDLE OF 40 TINES YELL	01
2	P50ZG074	HOOPE YELLOW	01
3	V10BZ006	SCREW TTQST M 10x21 UNI 5731 ZN	20
4	S10BZ001	CLIP TINE RAKE WHEELS ZN	10
5	P70AG069	PLATE/TINE	01
6	V20AZ003	HEXAGONAL NUT 6S M10 UNI 5588 ZINC	20
7	V10AZ015	HEX SCREW TE M10x25	06
8	V30AZ004	WASHER M10 UNI6592 ZN	06
9	V20AZ003	HEXAGONAL NUT 6S M10 UNI 5588 ZINC	06
10	S95AR001	CAP FOR HUB	01
11	V20BZ006	SELF LOCKING NUT NYLON MB18 UNI7474	01
12	V60A0001	BUSHING (CUSC.)	01
13	S10AR004	HUB W/GREASER	01
14	V60D0001	BUSHING (CUSC.) 6205 Z	01
15	V30AZ012	WASHER M24 UNI 6592 ZINCED	01
	P20AG001	RAKE WHEEL COMPLETE R.H. T YELLOW	
	P20AG002	RAKE WHEEL COMPLETE L.H.T.YELLOW	
	P20BG001	RAKE WHEEL COMPLETE R.H. STR.	
	P20BG002	RAKE WHEEL COMPLETE L.H. STR.YELLOW	



## PULL-TYPE HITCH ASSEMBLY RCS 8-10-12

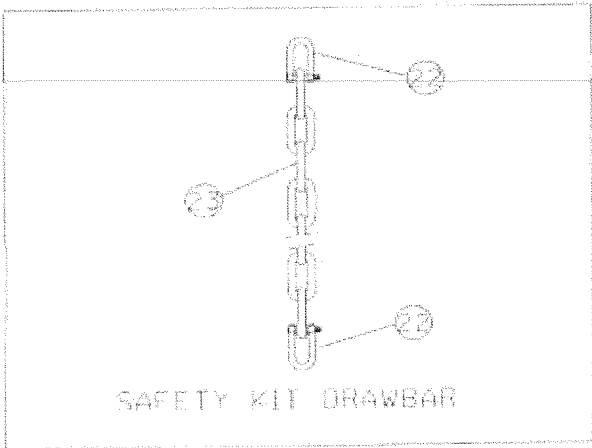
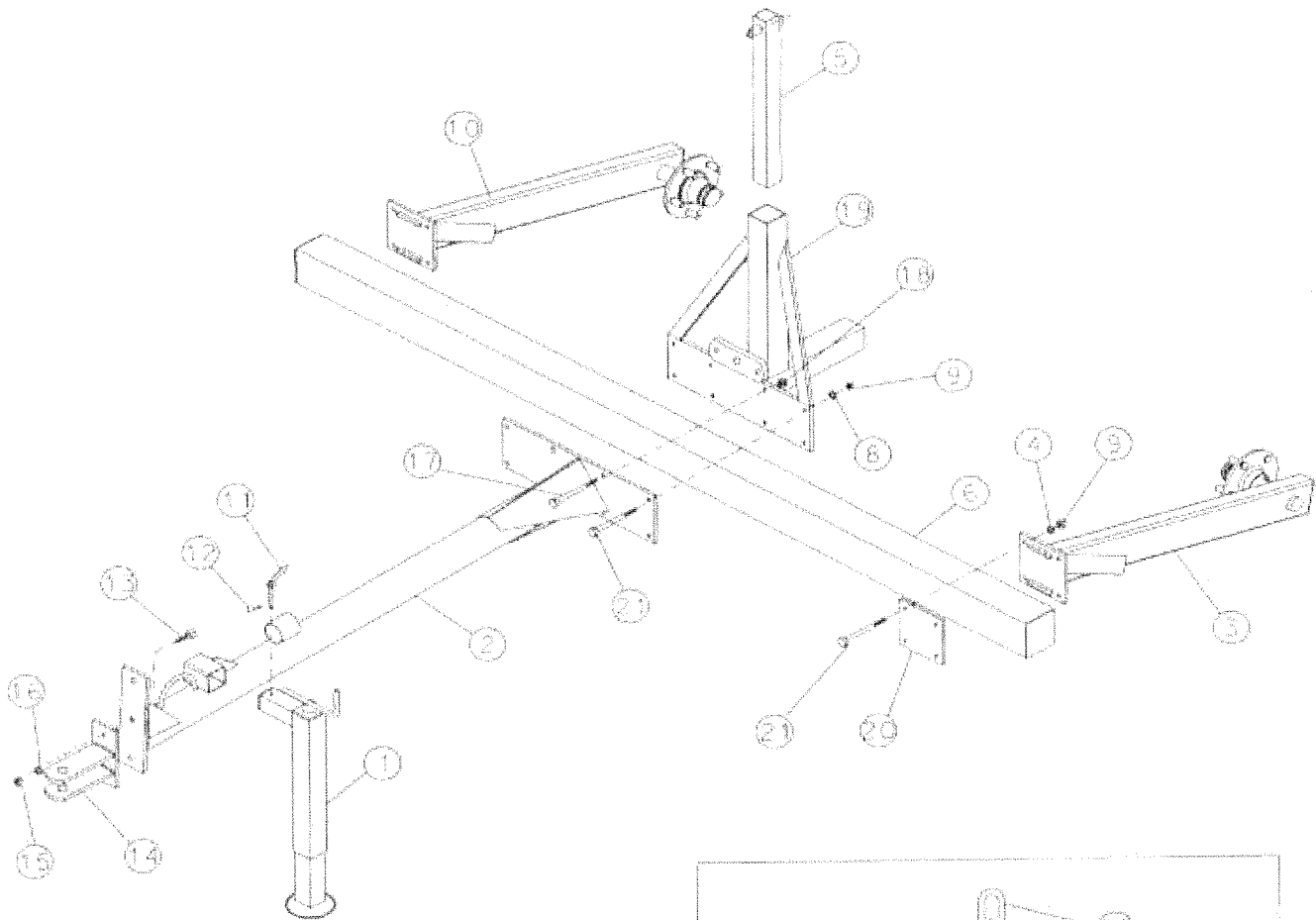

**PULL-TYPE HITCH ASSEMBLY RCS 8-10-12**

N#	CODE#	DESCRIPTION	Q.TY
1	P50ZR006	STAND COMPLETE FOR DRAWBAR	01
2	P50FR060	DRAWBAR RCS MOD. 2000	01
3	P50DR102	SUPPORT FOR WHEEL L.H. RCS	01
4	V30CZ004	SPRING LOCKWASHER M12 UNI1751 Z	08
5	P50RZ002	GUIDE FOR CYLINDER ZINCED RCS	01
6	P50AR002	TOOLBAR FRAME I=2100 RCS8	01
	P50AR003	TOOLBAR FRAME I=2560 RCS10	01
	P50AR001	TOOLBAR FRAME I=3000 RCS12	01
8	V30CZ004	SPRING LOCKWASHER M12 UNI1751 Z	04
9	V20AZ004	HEXAGONAL NUT 6S M12 UNI 5588 ZN	12
10	P50DR101	SUPPORT FOR WHEEL R.H. RCS	01
11	C70BZ001	PIN FOR STAND DRAWBAR D.12 ZINCED	01
12	V40CZ006	SPLIT PIN R D=2.5 ZINCED	01
13	V10AZ054	SCREW TE M16x40 UNI 5739 ZINCED	02
14	P50HR001	BRACKET ATTACHMENT TRACTOR RCS	01
15	V20AZ007	HEXAGONAL NUT 6S M16 UNI 5588 ZINC	02
16	V30CZ006	SPRING LOCK WASHER M16 UNI 1751 ZN	02
17	V10AZ051	SCREW TE M14x140 UNI 5737 ZINCED	04
18	V20CZ004	NUT METABLOCK M14 DIN 980 ZINCED	04
19	P50DR014	SUPPORT FOR STAND AND CYLINDER RCS	01
20	P70AZ032	PLATE FORK GROUND W.4 HOLES	02
21	V10AZ046	HEX.CAP SCREW TE M12x140 UNI 5737 Z	12
22	V50AZ002	U SHACKLE D=8 ROBUR ZINCED	03
23	C45AZ007	CHAIN 57x33x6 I=720 ZINCED	02

## TIRE AND WHEEL ASSEMBLY RCS 8-10-12

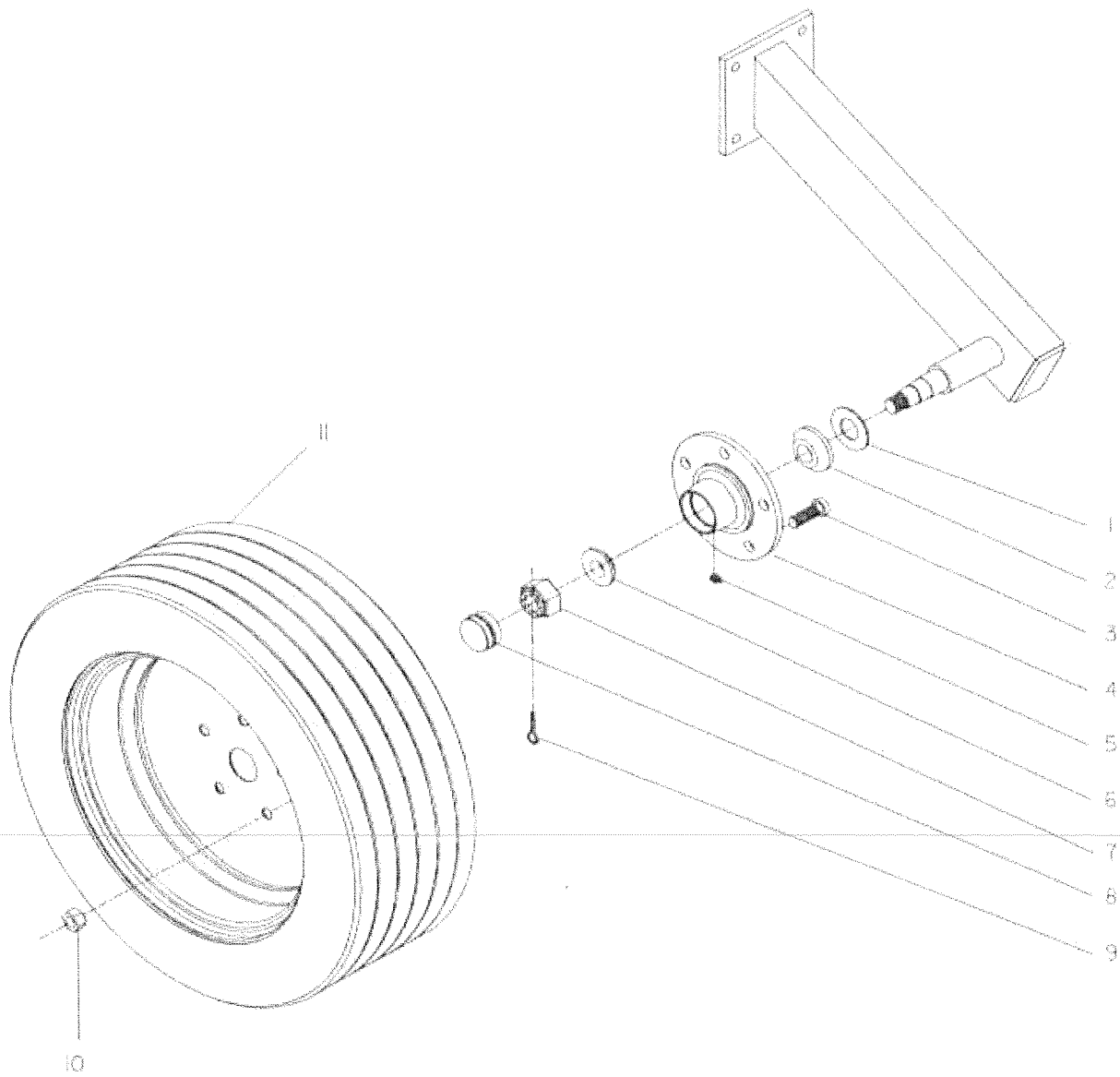

---

**TIRE AND WHEEL ASSEMBLY RCS 8-10-12**

№	CODE#	DESCRIPTION	Q.TY
1	V30A0015	SEAL WASHER 30-62	01
2	V60B0002	BUSHING (C/USC.) 30206	01
3	V10A0121	CAP SCREW MB 16x45	05
4	S10AR006	HUB WITH GREASER	01
5	V99AZ003	GREASER 6 MB UNI 7663-A	01
6	V60B0001	BUSHING (C/USC.) 30205	01
7	V20B0024	HEXAGONAL NUT/SPINDLE MB22	01
8	S95AZ002	CAP FOR HUB d=52	01
9	V40C0011	COTTER PIN D. 4,6 L=30	01
10	V20BZ025	SELF-CENTER NUT MB16x27x21	05
11	C60AS001	WHEEL 175/70 R14 4Jx14"	01

## KIT BLOCKING ONE RAKE RCS 8-10-12

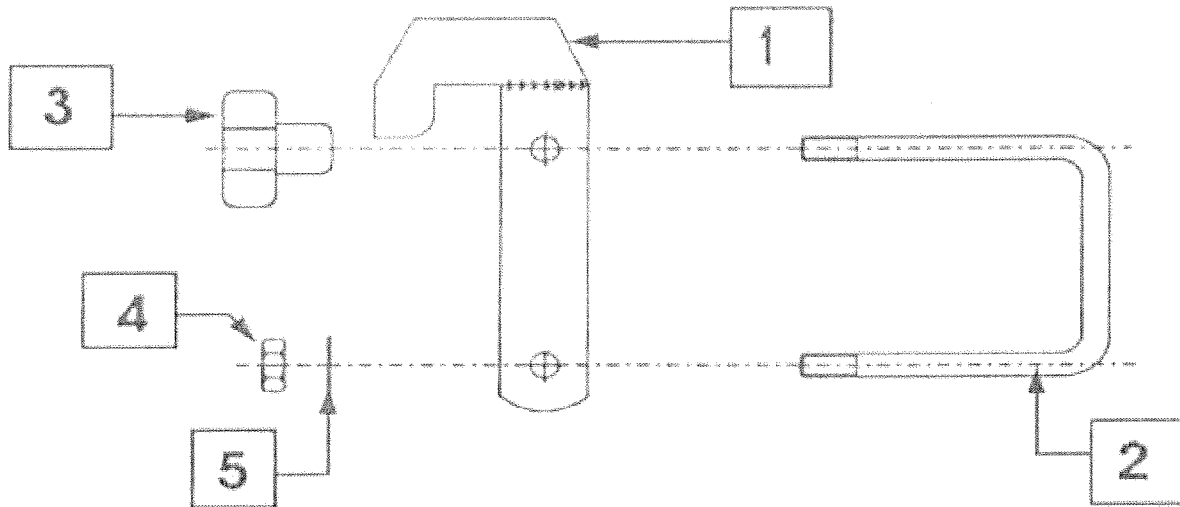

## SAFETY KIT FOR TRANSPORT RCS 8-10-12

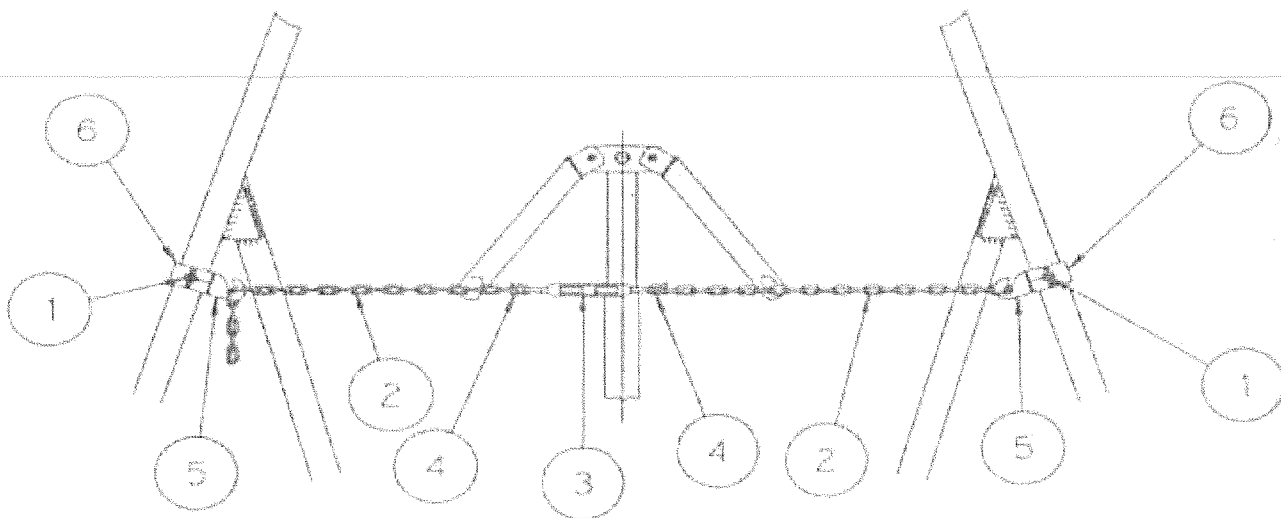

---

**KIT BLOCKING ONE RAKE RCS 8-10-12**

N#	CODE#	DESCRIPTION	Q.TY
1	P50ZZ093	KIT BLOCKING ONE RAKE FOR RCS	01
2	V70AZ002	U BOLT M12x102x125 ZINCED	01
3	V85Z0002	PLASTIC HANDLE M 12	01
4	V20AZ005	HEXAGONAL NUT 6S M12 UNI 5589 ZINC	01
5	V30AZ005	WASHER M12 UNI 6591 ZINCED	01
	C10D0022	KIT BLOCKING ONE RAKE FOR RCS	

---

**SAFETY KIT FOR TRANSPORT RCS 8-10-12**

N#	CODE#	DESCRIPTION	Q.TY
1	V10AZ016	SCREW TE M10x30 UNI 5739 ZINCED	04
	V20CZ002	NUT METABLOCK M10 DIN 980 ZINCED	04
2	C45AZ007	CHAIN 57x33x6 l=720 ZINCED	02
3	C30AZ007	TURNBUCKLE M12 ZINCED	01
4	V50AZ002	U SHACKLE D=8 ROBUR ZINCED	02
5	P50SZ010	SAFETY LOCK ZINCED RCS	02
6	P50SZ007	BRACKET FOR FRAME PIN ZINCED	02
	G10D0016	KIT SAFETY TRANSPORT RCS	

## KIT CENTRAL WHEEL S1 RCS 8-10-12

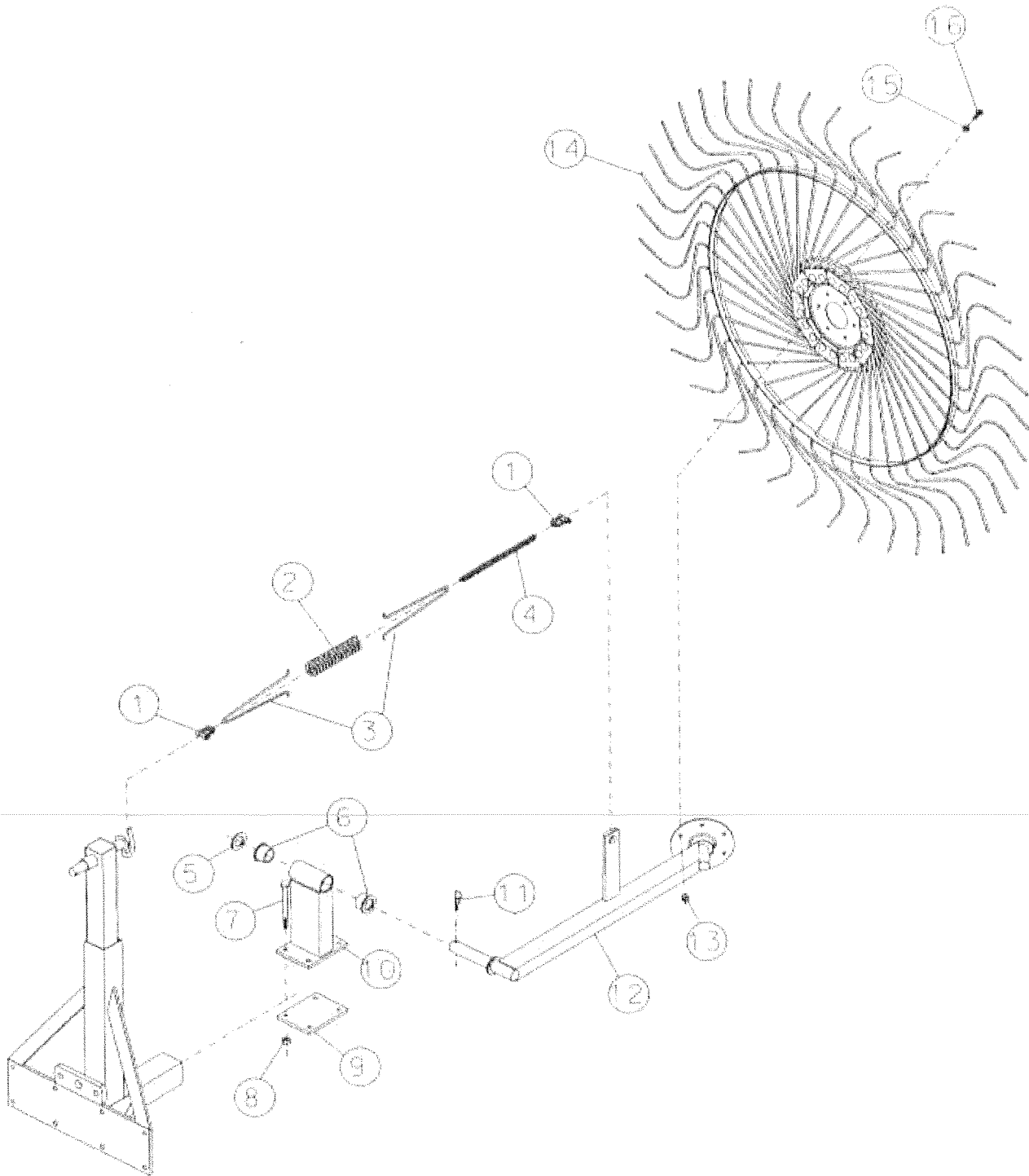

**KIT CENTRAL WHEEL S1 RCS 8-10-12**

NR	CODE#	DESCRIPTION	Q.TY
1	V50AZ001	U SHACKLE 1/4" ZN	02
2	C40AZ003	SPRING ZINCED	01
3	C40AZ033	SPRING ATTACH ZN	02
4	C45AZ001	CHAIN ZINCED RCS 23x10,7x4,5 I=506	01
5	V30BZ007	STEEL B. WASHER 32.2x53x6 ZN	01
6	V85A0001	BUSHING NYLON	02
7	V10AZ043	SCREW TE M12x110 UNI 5737 ZINCED	04
8	V20AZ004	HEXAGONAL NUT 6S M12 UNI 5588 ZN	04
9	P70AZ045	PLATE W/4 HOLE ZN S1	01
10	P50SR003	SUPPORT FOR RAKE ARM S1 FOR RCS	01
11	V40CZ009	SPLIT PIN R D=5 ZN	01
12	P50BR027	ARM CARRYING RAKE WHEEL S1 FOR RCS	01
13	V20AZ003	HEXAGONAL NUT 6S M10 UNI 5588 ZINC	06
14	P20BG001	RAKE WHEEL COMPLETE R.H. STR.	01
15	V30AZ004	WASHER M10 UNI6592 ZN	06
16	V10AZ015	HEX SCREW TE M10x25	06



HYDRAULIC CYLINDER ASSEMBLY RCS 8-10-12

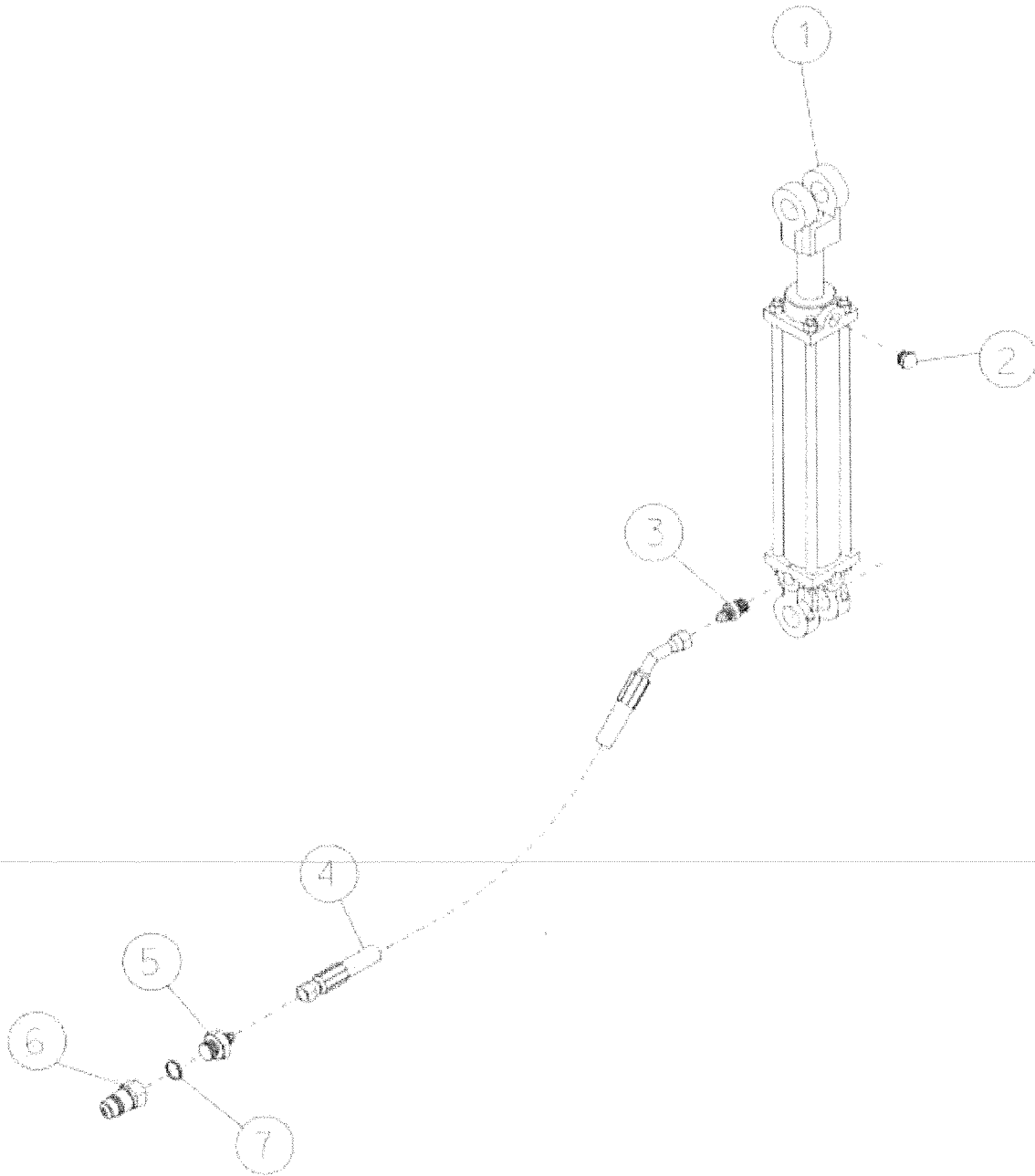

---

**HYDRAULIC CYLINDER ASSEMBLY RCS 8-10-12**

N#	CODE#	DESCRIPTION	Q.TY
1	C50BN003	HYD. CYLINDER	01
2	C25L0001	VALVE FOR CYLINDER 3/8"	01
3	C25A0003	FITTING F3 3/8" NPTF-9/16-18	01
4	C22A0007	HOSE SAE100 R1 3/8" L=2800	01
5	C25H0001	RESTRICTOR 9/16"-18JIC M-1/2" M	01
6	C25E0001	FAST FLUID CONNECTOR 1/2" PIONEER	01
7	C25F0010	WASHER+OR 1/2" GAS CYL.	01

## NUMERICAL INDEX

PART N#	PAGE N#	REF N#	PART N#	PAGE N#	REF N#	PART N#	PAGE N#	REF N#
C10D0016	17		P50AR156	7	7	V10AZ046	1	7
C10D0022	17		P50AR157	7	6	V10AZ046	13	21
C22A0007	19	4	P50BR006	5	3	V10AZ051	13	17
C25A0003	19	3	P50BR007	5		V10AZ054	13	13
C25E0001	19	6	P50BR014	3		V10AZ057	1	9
C25F0010	19	7	P50BR014	5		V10AZ057	9	4
C25H0001	19	5	P50BR014	7		V10AZ059	9	5
C25L0001	19	2	P50BR015	3	2	V10AZ066	1	26
C30AZ005	9		P50BR015	5	2	V10AZ075	9	6
C30AZ006	9	11	P50BR015	7	2	V10AZ081	1	10
C30AZ007	17	3	P50BZ058	9	1	V10AZ099	1	11
C30AZ008	7	11	P50BZ059	9	2	V10BZ005	11	3
C30BZ001	1	24	P50DR003	13	10	V20AZ003	11	6
C40AZ024	1	18	P50DR004	13	3	V20AZ003	11	9
C40AZ030	1	22	P50DR011	1	1	V20AZ004	1	12
C45AZ003	7	4	P50DR012	1	2	V20AZ004	13	9
C45AZ007	13	23	P50DR014	13	19	V20AZ005	17	4
C45AZ007	17	2	P50FR060	13	2	V20AZ007	13	15
C50BN003	9	14	P50HR001	13	14	V20B0024	15	6
C50BN003	19	1	P50HZ032	9	13	V20BZ006	11	11
C60AG001	15	11	P50NR019	1	3	V20BZ007	1	25
C60AG001	15		P50RZ002	13	5	V20BZ019	1	14
C60B0007	15	9	P50SZ007	17	6	V20BZ019	9	8
C70AZ001	1	23	P50SZ010	17	5	V20BZ021	1	15
C70AZ002	3	3	P50UR006	7	8	V20BZ025	15	10
C70AZ002	5	5	P50ZG074	11	2	V20CZ002	1	16
C70AZ002	7	3	P50ZR002	1		V20CZ002	7	12
C70AZ003	1	20	P50ZR003	1	4	V20CZ002	17	
C70BZ001	13	11	P50ZR004	1		V20CZ003	5	7
C70BZ002	9	17	P50ZR005	1	5	V20CZ004	13	18
C70BZ003	1	8	P50ZR006	13	1	V20CZ005	1	13
C70BZ006	1	6	P50ZZ040	1	27	V20CZ005	9	7
C70BZ012	9	15	P50ZZ070	7	13	V30A0015	15	1
C70CZ001	9	12	P50ZZ093	17	1	V30AZ004	11	8
P20AG001	11		P70AG059	11	5	V30AZ005	17	5
P20AG002	11		P70AZ032	13	20	V30AZ008	9	3
P20BG001	11		P70AZ036	9	9	V30AZ012	11	15
P20BG002	11		S10AR001	15	4	V30AZ014	9	18
P25AG001	11		S10AR004	11	13	V30CZ004	1	17
P25AG002	11		S10BZ001	11	4	V30CZ004	13	4
P25AG003	11	1	S95A0002	15	7	V30CZ004	13	8
P50AR001	13		S95AR001	11	10	V30CZ006	13	16
P50AR002	13	6	V10A0121	15	3	V40C0011	15	8
P50AR003	13		V10AZ015	11	7	V40CZ006	13	12
P50AR006	7	5	V10AZ016	7	9	V40CZ008	1	19
P50AR009	3	1	V10AZ016	17	1	V40CZ008	3	4
P50AR010	5	1	V10AZ039	5	6	V40CZ008	5	4

## NUMERICAL INDEX

PART N#	PAGE N#	REF N#	PART N#	PAGE N#	REF N#	PART N#	PAGE N#	REF N#
V40CZ008	7	1						
V40CZ008	9	16						
V45BZ001	9	10						
V50AZ002	7	10						
V50AZ002	13	22						
V50AZ002	17	4						
V60A0001	11	12						
V60B0001	15	5						
V60B0002	15	2						
V60D0001	11	14						
V70AZ002	17	2						
V85Z0002	17	3						
V99AZ001	1	21						